

Comparison of Cervical Stabilization with Transpedicular Pins and Polymethylmethacrylate versus Transvertebral Body Polyaxial Screws with or without an Interbody Distractor in Dogs

Paulo V.T. Marinho¹ Cassio R.A. Ferrigno² Ronaldo C. da Costa³ César A.M. Pereira⁴
Mário A.F. Rego⁵ Thales Bregadioli⁵ Fernanda Paes⁵

¹ Department of Veterinary Medicine, Federal Institute of Education, Science, and Technology of Southern Minas Gerais, IFSULDEMINAS, Muzambinho, MG, Brazil

² Small Animal Clinical Science, University of Tennessee, Knoxville, United States

³ Department of Veterinary Clinical Sciences, The Ohio State University, Columbus, Ohio, United States

⁴ Biomechanics Laboratory LIM-41/HG-FMUSP, Hospital das Clínicas, College of Medicine, University of São Paulo, São Paulo, Brazil

⁵ Department of Surgery, University of São Paulo, São Paulo, Brazil

Address for correspondence Paulo V.T. Marinho, DMV, MS, PhD, Department of Veterinary Medicine, Muzambinho Road, km 35 - Morro Preto, Muzambinho 37890-000, Brazil
(e-mail: paulo.marinho@muz.ifsuldeminas.edu.br).

Vet Comp Orthop Traumatol 2022;35:289–297.

Abstract

Objective The main aim of this study was to compare the biomechanical properties of caudal cervical vertebral stabilization using bicortical transpedicular pins with polymethylmethacrylate (PMMA) versus transvertebral body polyaxial screws and connecting rods with or without an interbody distractor.

Study Design Ten canine cervical vertebral columns (C2–T3) were used. Four models (intact, transvertebral body polyaxial screw with interbody distractor [polyaxial + distractor], transvertebral body polyaxial screw without interbody distractor [polyaxial – distractor] and bicortical transpedicular pins/polymethylmethacrylate [pin-PMMA]) were applied to C6–7 sequentially on the same specimens. Angular range of motion (AROM) in the form of flexion and extension was measured at C4–5, C5–6 and C6–7 in all groups.

Results Treated vertebral specimens had significantly less AROM than unaltered specimens. There was no significant difference in AROM between the experimental groups at C6 and C7. Angular range of motion ratio in flexion–extension was 80.8, 72.7 and 78.3% for polyaxial + distractor, polyaxial – distractor and pin-PMMA groups, respectively, which were less than the intact group. There was no significant increase in the range of motion of the adjacent vertebrae after stabilization.

Conclusion Stabilization obtained with transvertebral body polyaxial screws was comparable to that from the well-established bicortical pins/PMMA construct. Association of an intervertebral distractor did not change AROM of the polyaxial screw constructs.

Keywords

- ▶ vertebral fusion
- ▶ bone screws
- ▶ biomechanics
- ▶ cervical vertebral column
- ▶ dogs

received

June 21, 2021

accepted after revision

February 11, 2022

published online

June 20, 2022

© 2022. Thieme. All rights reserved.

Georg Thieme Verlag KG,
Rüdigerstraße 14,
70469 Stuttgart, Germany

DOI <https://doi.org/>

10.1055/s-0042-1744490.

ISSN 0932-0814.

Introduction

Various methods for vertebral distraction–stabilization have been used for the treatment of cervical spondylomyelopathy (CSM).^{1–6} Of these, the combination of bicortical transpedicular pins and polymethylmethacrylate (PMMA) placed into vertebral bodies^{1,4} has been associated with an unacceptable rate of penetration into the vertebral canal and intervertebral foramen.⁷ Clinical reports and biomechanical studies suggest that transvertebral body screws/PMMA or locking plates are effective in stabilizing the vertebral column of dogs with CSM.^{8–14} The addition of an interbody spacer in these constructs significantly increases stiffness.^{13,14}

Monoaxial or polyaxial pedicle screws are used for vertebral stabilization in dogs.^{15,16} Biomechanical studies on pedicle screws have been performed in synthetic models,¹⁷ canine cadavers¹⁸ and *in vivo*^{19,20} to stabilize the lumbosacral spine after decompressive surgery, resulting in efficient stabilization.^{18,19,21} In synthetic models with critical failure, the use of pedicular monoaxial screws was more rigid than fixation with pins and PMMA.¹⁷ In humans, pedicle screws are used in cases of vertebral instability or for vertebral fusion.^{15,16,22–27}

The biomechanics of transvertebral body polyaxial screws in stabilizing the cervical vertebral column have not been described in dogs. Our objective was to compare bicortical screws/PMMA and transvertebral body polyaxial screws with or without an interbody distractor in the caudal cervical vertebral column of dogs, and analyse their effect on adjacent cranial segments. We hypothesized that each implant would significantly decrease angular range of motion (AROM) of the vertebral segments and that addition of an intervertebral disk spacer would increase AROM compared with specimens instrumented without a spacer.

Materials and Methods

Sample

Ten vertebral column segments (C2–T3) from mature large dogs (25–35 kg) that died for reasons unrelated to this study were used. All vertebral column segments were removed with the surrounding musculature and had lateral and ventrodorsal radiographs. Sagittal T2-weighted magnetic resonance images were obtained with a 0.23T scanner (Vet Grande MRI 0.23T, Esaote, Italy). Inclusion criteria were the absence of vertebral/spinal imaging abnormalities (e.g. fracture, luxation, intervertebral disk degeneration).

All procedures were performed according to and with approval of the Ethics and Animal Care Committees of the Faculty of Veterinary Medicine and Animal Science of the University of São Paulo, registered under register number 3869220116.

Specimen Preparation

Spinal segments were stored at -20°C . One day prior to the biomechanical tests, they were transferred to a refrigerator at $+4^{\circ}\text{C}$ to defrost. On the day of the tests, spines were

defrosted at room temperature and kept moist in a NaCl 0.9% solution.

Prior to the tests, C2 and the vertebral bodies of T2 and T3 were fixed in autopolymer acrylic resin. This segment was chosen to try and represent the normal motion of the neck, which has its pivot in the thoracic region and more freedom of movement in the cervical region.^{28,29} Excess paravertebral soft tissue was removed, but most of the epaxial musculature, spinal ligaments and joint capsules were preserved.

Biomechanical Testing

The testing apparatus (Model KE3000MP, series M1012931, and 100 kgf cell load, São Paulo, Brazil) was composed of an articulating base and metal cup, connected to a 100 kgf load cell, where the distal and proximal segments of the specimen were fixed using screws and PMMA. Movement of the cups mimicked the forces of the arching of the vertebral column. Specimens were initially fixed at the zero-load programmed into the machine in a neutral position (→ Fig. 1). No axial load was applied. Position of the fixed vertebral column segment followed previous descriptions.^{29,30}

Initially, a pilot study was performed to choose a torque where maximum dislocation would not result in non-elastic deformation. Sequential and repeated torques of $\pm 1\text{ Nm}$, $\pm 2\text{ Nm}$ and $\pm 3\text{ Nm}$ were applied in flexion and extension to two vertebral spinal column segments which met the inclusion criteria. A torque greater than $\pm 2\text{ Nm}$ caused non-elastic deformation in some repetitions. This was characterized by a sudden increase in angular deformation without a concomitant increase in load applied in flexion and extension, which possibly reflected the failure of one or more ligamentous support structures. The specimens used in the pilot study were not reused for the main study. Based on the results from the pilot study and previously published studies,^{31–33} the torque was limited to $\pm 2\text{ Nm}$.

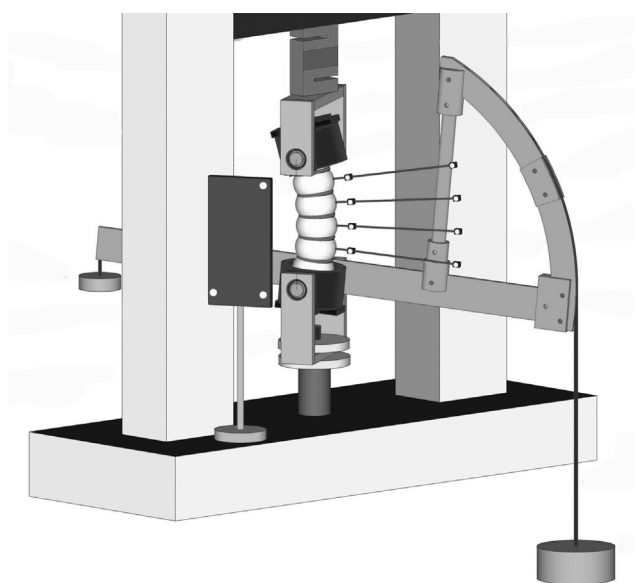

Fig. 1 Schematic drawing of the final assembly used for biomechanical tests of canine cervical vertebral column.

Test Conditions

Four markers were placed in each specimen, positioned at C4, C5, C6 and C7, using 1.5-mm diameter Steinmann pins inserted into the centre of the vertebral bodies (to the right of the spinous processes) (►Fig. 1).

Prior to data collection, each specimen was preconditioned and submitted to two cycles of full extension and flexion.³⁴

The load was applied to each segment for 60 seconds, with 120 seconds between each cycle to allow for recovery of the initial length of elastic tissues.^{12,34} Extension and flexion were performed sequentially in each specimen, based on previous studies.^{30,33,34}

Tests were first performed on the vertebral column segments without the implants. The same segments were then modified and tested as part of the polyaxial + distractor group, polyaxial – distractor group and pin-PMMA group. Samples were kept moist during biomechanical testing.

Photogoniometry

For each group, AROM in flexion and extension for the treated segment (C6–7) and adjacent cranial segments (C4–5 and C5–6) were calculated using a photogoniometry (Borland Software Corporation–Austin, EUA) system.^{35,36}

The camera (Canon, Model EOS Digital Rebel XT, EUA) was positioned at a distance of 2.2 m from the specimen and at 1 m of height, to keep the camera sensor parallel to the marker plane and test gauge. The camera was shot via remote control to register an image at moment zero, before application of the load, and after the first, second and third repetitions, and after 60 seconds of load application, registering eight images per group (four for flexion and four for extension). The camera registered a total of 32 images per vertebral column for all groups.

The angles between the markers were analysed via a Delphi-based ((Borland Software Corporation–Austin, EUA) computer software, which allowed automatic analysis of the photos.

Study Groups

Four experimental groups were created: Intact group (intact cervical vertebral column), polyaxial + distractor group (transvertebral body polyaxial screws with an interbody distractor), polyaxial–distractor group (transvertebral body polyaxial screws without an interbody distractor) and pin-PMMA group (bicortical Shanz pins and PMMA).

All 10 cervical vertebral column segments were used for each group. The intervertebral space at C6–7 received implants and was the treated vertebral motor unit (VMU), and C4–5 and C5–6 were the cranial adjacent VMUs.

Polyaxial + Distractor Group

Prior to placement of the polyaxial screws, a partial discectomy with ~10 mm in width was performed for placement of an interbody distractor (Focus Orthopedic Products, Indaiatuba, São Paulo, Brazil).⁸ The pure titanium interbody distractor has a conical shape (Standard Specification for Unalloyed Titanium, for Surgical Implant Applications

[UNS R50250, UNS R50400, UNS R50550, UNS R50700]) with a core diameter of 7.96 mm to 5 mm in diameter from base to tip, respectively, and 16.5 mm in length. The conical angulation is 12 degrees, and pitch of 2.25 mm.

The ventral annulus fibrosus, nucleus pulposus and part of the remaining annulus were removed, leaving only a thin rim of annulus intact along the lateral and dorsal borders. A sharp curette and/or high-speed drill were used to debride the endplates of the exposed vertebral extremity before applying the distractor.

Six 3.5-mm-diameter and 12-mm-length titanium alloy (Standard Specification for Wrought Titanium-6Aluminum-4Vanadium ELI–Extra Low Interstitial–Alloy for Surgical Implant Applications [UNS R56401]) polyaxial screws ((Focus Orthopedic Products, Indaiatuba, São Paulo, Brazil) were inserted into the cranial and caudal portion of the vertebral bodies of C6 and 7.¹³ On the left side, one screw was inserted in the vertebral body of C6 and two in the body of C7, along the longitudinal axis. The first titanium connecting bar (5 mm in diameter and 8 cm in length) was then fixed using titanium alloy set screw. On the contralateral side, two screws were placed in the vertebral body of C6 and one in the body of C7, to which another connecting bar was fixed (►Fig. 2A). The screws were directed perpendicular to the axis of the bone at C6 and 7 and inserted until fully penetrating the vertebral body (►Fig. 3). The connecting bars (Standard Specification for Wrought Titanium-6Aluminum-4Vanadium ELI–Extra Low Interstitial–Alloy for Surgical Implant Applications [UNS R56401]) were fixed parallel to each other and to the ventral plane of the vertebral column. The set screws were tightened after insertion of the connecting bar over the tulips. Screws were gradually tightened so that the final tightening was only done after the bar was completely settled and fixed over the screws.

Polyaxial–Distractor Group

The interbody distractor was removed in an anticlockwise manner so that the polyaxial screws were kept intact and vertebral distraction maintained. Fixation of the set screws with the bar was checked and adjusted as needed, ensuring stability of the system. Implants were those described for the polyaxial + distractor except for the absence of an interbody distractor (►Fig. 2B).

Pin-PMMA Group

Polyaxial screws were removed prior to insertion of bicortical transpedicular pins. Two 3-mm-diameter positive profile stainless steel cortical pins were placed into each vertebral body at C6 and 7.⁴ Pin placement was started on ventral midline and angled 30 to 40 degrees from the sagittal plane into the vertebral pedicle with the goal of engaging the trans-cortex (►Fig. 3C). Care was taken to avoid the previous holes left by the screws. Pins were cut leaving 12 to 15 mm protruding from the ventral vertebral body surface to allow incorporation into bone cement (Baumer do Brasil Ltda, Jundiaí, Brazil).¹⁴

The specimens were linearly distracted along the axial axis. The distraction prior to hardening of the bone cement

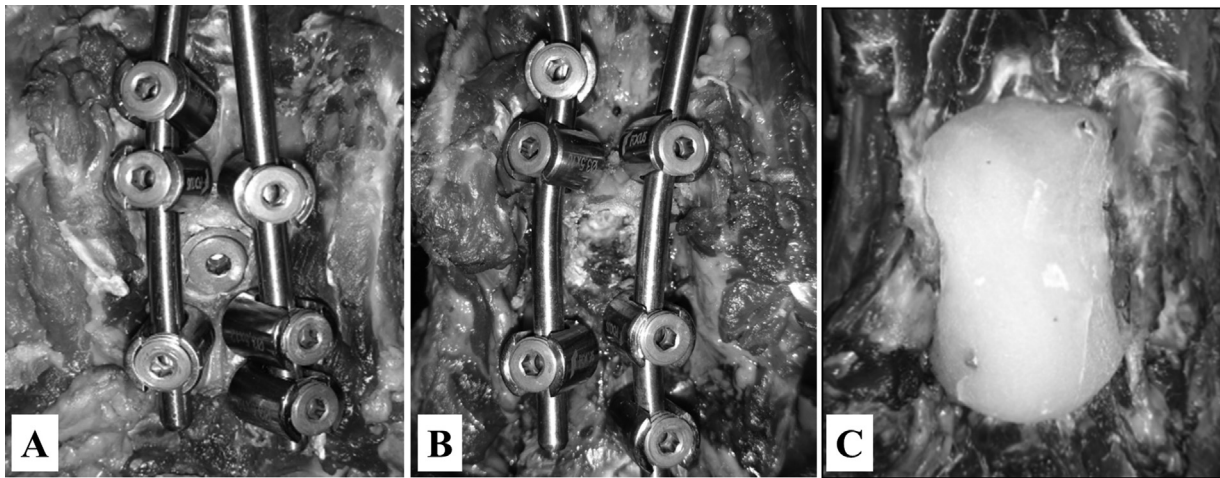

Fig. 2 Photographic images of the cervical vertebral column after fixation of vertebral segment C6–7 using (A) polyaxial screws and connecting bars with an interbody distractor (polyaxial + distractor model), (B) polyaxial screws with connecting bars without an interbody distractor (polyaxial–distractor model) and (C) using bicortical pins and PMMA (pin-PMMA model). In each vertebral specimen, the models were tested sequentially (intact model, polyaxial + distractor model, polyaxial–distractor model and finally the pin-PMMA model). PMMA, polymethylmethacrylate.

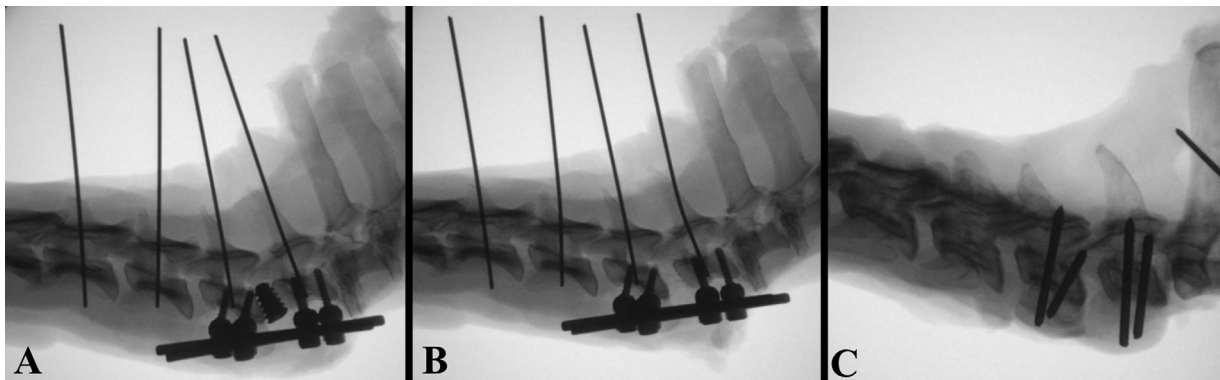

Fig. 3 Representative lateral radiographic views showing fixation of C6–c7 using a polyaxial + distractor model (A), polyaxial–distractor model (B), and a pin-PMMA model (C). PMMA, polymethylmethacrylate.

was done to prevent collapse of the disk space and to maintain distraction, as previously described.³⁰ Bone cement was mixed at room temperature and placed into the mould while the sample was held in place for a minimum of 20 minutes. The amount of bone cement used was standardized as 25 mL of the methyl methacrylate polymer and 10 mL of the methacrylate polymer monomer, which sufficed to reach the tip of the inserted and cut pins at a height of ~3 cm, and width and length that encompassed the ventral portion of the vertebral bodies being fixed (→ Fig. 2C).

Correct implant placement for all groups was confirmed via radiographs (→ Fig. 3).

Statistics

Biomechanical data were compared between specimens (unaltered vs. treated) and between treatments (polyaxial + distractor vs. polyaxial–distractor vs. pin-PMMA).

The mean was calculated from three repetitions of angle measurements at C4–5, C5–6 and C6–7 per group. The difference between the angles of the vertebrae before and after application of the loads (angular difference) was

calculated in each situation. The mean from the three repetitions of the force registered at maximum dislocation was obtained for each group.

Data were obtained for flexion and extension. The AROM in flexion–extension was a result of the sum of the angles between the vertebrae in flexion and extension.

For parametric data (normal distribution and equal variance), analysis of variance (ANOVA) was used for comparison between groups, and ANOVA for repeated measurements for comparison between different degrees within each group. A post-hoc Tukey test was used to identify in which groups/degrees a difference was observed.

For flexion versus extension analyses, normal distribution of differences between the intact and other groups were analysed using the Shapiro–Wilk test. The pin-PMMA group (at C4–5 and C5–6) did not have normal distribution, thus the paired Wilcoxon test was used for comparing extension and flexion. For the other comparisons, a paired Student's *t*-test was used.

For analysis within the same AROM group in groups intact and pin-PMMA, Friedman's test was used, followed by the

Nemenyi test. For the polyaxial + distractor and polyaxial-distractor groups, repeated measure ANOVA was used, followed by post-hoc Tukey. For analysis between groups, the Kruskal-Wallis test was used.

For comparing extension between groups, Kruskal-Wallis was used. To compare the different degrees within the polyaxial + distractor and pin-PMMA, the Friedman test was used. Results were considered significant if $p < 0.05$.

Results

Flexion

Within the same group in the polyaxial + distractor, polyaxial-distractor and pin-PMMA groups, the angular difference was significantly smaller at the C6-7 intervertebral space when compared with C4-5 and C5-6.

When comparing groups, the AROM in flexion at C6-7 in the polyaxial + distractor, polyaxial-distractor and pin-PMMA groups were 72, 59.9 and 68.6%, respectively, less than the AROM of the intact vertebral columns ($p < 0.0001$). There was no significant difference in AROM between polyaxial + distractor, polyaxial-distractor and pin-PMMA groups. For flexion, there was no significant difference in angular difference for the adjacent intervertebral spaces C4-C5 ($p = 0.938$) and C5-6 ($p = 0.328$) between the four groups (► Table 1).

Extension

The AROM in extension was significantly smaller for the treated groups in the C6-7 intervertebral space, with AROM being 92.5, 89.6 and 91% less in the polyaxial + distractor, polyaxial-distractor and pin-PMMA groups, respectively, when compared with the intact segment. There was no significant difference in the AROM between groups at C6-7 or at C4-5 and C5-6 (► Table 2).

Flexion-Extension Angular Range of Motion

Angular range of motion in flexion-extension was similar to flexion and extension results. Stiffness during flexion-extension at C6-7 for polyaxial + distractor, polyaxial-distractor and pin-PMMA groups was 80.8, 72.7, and 78.3% greater than that of the intact specimens respectively ($p = 0.00004$). There was no significant difference in stiffness between polyaxial + distractor, polyaxial-distractor and pin-PMMA groups.

Range of motion of the adjacent vertebrae was not influenced by vertebral stabilization and did not show a significant increase regardless of method used. However, there was a trend for increase in AROM between C5 and 6 in the pin-PMMA group, when compared with polyaxial + distractor and polyaxial-distractor groups ($p = 0.05265$) (► Table 3).

Table 1 Mean angular difference (degrees) (mean \pm standard deviation) between the groups after ventral flexion of the cervical vertebral column of dogs

Group	Angular difference			p-Value
	C4-5	C5-6	C6-7	
Intact	5.74 \pm 2.2 ^{A,a}	6.63 \pm 2.93 ^{A,a}	7.7 \pm 2.93 ^{A,a}	0.285
Polyaxial + distractor	5.55 \pm 1.96 ^{A,a}	5.38 \pm 1.99 ^{A,a}	2.17 \pm 1.35 ^{B,b}	< 0.001
Polyaxial-distractor	5.4 \pm 1.83 ^{A,a}	4.85 \pm 1.55 ^{A,a}	3.09 \pm 1.82 ^{B,b}	0.016
Pin-PMMA	5.14 \pm 2.6 ^{A,a}	5.87 \pm 2.09 ^{A,a}	2.42 \pm 1.99 ^{B,b}	0.005
p-Value	0.938	0.328	< 0.001	

Abbreviation: Pin-PMMA, pins/polymethylmethacrylate.

^{A,B}—significant difference ($p < 0.05$) of angular difference between groups (i.e. between rows).

^{a,b}—significant difference ($p < 0.05$) of angular difference within the same group (i.e. between columns).

Table 2 Mean angular difference (degrees) (mean \pm standard deviation) between groups after extension of the cervical vertebral column of dogs

Group	Angular difference (degrees)			p-Value
	C4-5	C5-6	C6-7	
Intact	5.22 \pm 2.37 ^{A,a}	3.45 \pm 2.12 ^{A,a}	5.87 \pm 2.61 ^{A,a}	0.08
Polyaxial + distractor	4.79 \pm 1.76 ^{A,a}	2.82 \pm 1.66 ^{A,a}	0.44 \pm 0.44 ^{B,b}	<0.001
Polyaxial-distractor	4.94 \pm 1.86 ^{A,a}	3.15 \pm 1.99 ^{A,b}	0.61 \pm 0.43 ^{B,c}	< 0.001
Pin-PMMA	7.08 \pm 2.45 ^{A,a}	6.69 \pm 4.68 ^{A,a}	0.53 \pm 0.49 ^{B,b}	<0.001
p-Value	0.104	0.113	< 0.001	

Abbreviation: Pin-PMMA, pins/polymethylmethacrylate.

^{A,B}—significant difference ($p < 0.05$) of angular difference between groups (i.e. between rows).

^{a,b,c}—significant difference ($p < 0.05$) of angular difference within the same group (i.e. between columns).

Table 3 Mean (\pm standard deviation) difference of angular range of motion (degrees) in flexion–extension between the groups after ventral flexion and extension of the cervical vertebral column of dogs

Group	Angular difference (degrees)			p-Value
	C4–5	C5–6	C6–7	
Intact	10.96 \pm 3.5 ^{A,a}	10.08 \pm 3.42 ^{A,a}	13.57 \pm 4.52 ^{A,a}	0.103
Polyaxial + distractor	10.34 \pm 2.83 ^{A,a}	8.2 \pm 2.98 ^{A,a}	2.61 \pm 1.33 ^{B,b}	<0.001
Polyaxial–distractor	10.34 \pm 2.71 ^{A,a}	8.0 \pm 3.07 ^{A,a}	3.7 \pm 1.64 ^{B,b}	<0.001
Pin-PMMA	12.22 \pm 3.11 ^{A,a}	12.56 \pm 5.21 ^{A,a}	2.95 \pm 2.1 ^{B,b}	0.002
p-Value	0.596	0.0527	<0.001	

Abbreviation: Pin-PMMA, pins/polymethylmethacrylate.

^{A,B}—significant difference ($p < 0.05$) of angular difference between groups (i.e. between rows).

^{a,b}—significant difference ($p < 0.05$) of angular difference within the same group (i.e. between columns).

Table 4 Comparison of the mean angular difference (degrees) (mean \pm standard deviation) between flexion and extension within the same group and for the same vertebral segment obtained via subtraction of the mean values of the intact group and mean values in the other groups

Groups	C4–5		C5–6		C6–7	
	Extension	Flexion	Extension	Flexion	Extension	Flexion
Polyaxial + distractor	0.43 \pm 0.93	0.19 \pm 0.85	0.63 \pm 1.58	1.25 \pm 1.17	5.43 \pm 2.82	5.53 \pm 2.56
Polyaxial–distractor	0.28 \pm 1.09	0.34 \pm 1.56	0.3 \pm 1.69	1.78 \pm 1.66	5.26 \pm 2.87	4.61 \pm 2.48
Pin-PMMA	–1.86 \pm 2.49	0.6 \pm 2.69	–3.24 \pm 4.10 ^a	0.76 \pm 2.04 ^b	5.34 \pm 2.49	5.28 \pm 3.57

Abbreviation: Pin-PMMA, pins/polymethylmethacrylate.

^{a,b}—significant difference ($p < 0.05$) between extension and flexion values for C5–6.

Flexion versus Extension

The comparison between mean angular differences in flexion and extension within the same group showed significant differences only for C5–6 in the pin-PMMA group ($p = 0.04883$) (–Table 4). However, this difference was not seen at C6–7: polyaxial + distractor ($p = 0.9335$), polyaxial–distractor ($p = 0.5988$) and pin-PMMA ($p = 0.969$).

Discussion

The association of an intervertebral distractor with transvertebral body polyaxial screws and connecting bars or the use of polyaxial screws and connecting bars were viable for use on the ventral cervical vertebral column, with similar stability to bicortical fixation with pins and PMMA.^{1,6}

Distraction and/or stabilization, without removing the dorsal annulus, have contributed to the neurologic improvement in dogs with disk-associated CSM.⁸ Distraction decreases the effects of disk protrusion and ligament thickening, and eliminates the dynamic component of spinal cord compression.⁸ A study using human cadavers with cervical vertebral stenosis reported that a mean distraction of 7.5 mm led to a 50% increase in the transverse area of the vertebral canal.³⁷ The mechanical stability provided by the transvertebral body polyaxial screws in the vertebral bodies, with or without an interbody distractor, could be useful in patients with CSM.

Photogrammetry, used for measuring the angles before and after torque was applied, was initially described for

measuring range of motion in human knees.³⁸ Other studies in the vertebral column³⁵ and human knees³⁶ saw a minimum error in this method. Reflective markers placed in cervical vertebrae and photographic images have also been used to calculate the angular difference during flexion and extension.³⁵

Polyaxial screws allowed an adequate degree of freedom when directing the screws in the vertebral body and greater versatility during placement of the connecting bar. The screw head portion of the polyaxial screw that remains outside the vertebral body maintains a freedom of movement which allows easy insertion of the bar in the screw head before tightening the set screws and fixating the connecting bar. Since the orientation of each screw will not be the same as the next screw, this is advantageous when compared with monoaxial pedicle screws. Monoaxial screws have no mobility between the body of the screw and the connector and are restricted to situations where angulation is not an issue. Polyaxial screws are also more stiff than a monoaxial system, likely due to better coupling of the connecting bars to the cups, allowing better adaptation of the screw to the longitudinal nail.³⁹

In the *ex vivo* canine cervical column, the use of transvertebral body screws was biomechanically equivalent to bicortical transpedicular positive threaded pins with PMMA; however, the effects of cyclic loading on these implants with vertebral bridging have not been studied *in vitro*.¹² In our study, this comparison was done using transvertebral body polyaxial screws and connecting bars instead of screws and

PMMA. There was also no significant difference in stiffness. Polyaxial screws and connecting bars are biomechanically similar to locking plates. They act as internal fixators, creating a stiff bar-screw system, which provide angular stability independent from the friction of the bar or screw against the bone, but resulting from friction of the screw and bar interface, as well as allowing adequate blood perfusion under this interface.⁴⁰

The addition of an intervertebral spacer significantly increased the stiffness of a monocortical transvertebral body screws and PMMA construct.¹³ In our study, despite the lower values of angular difference in the polyaxial + distractor group when compared with the polyaxial-distractor and pin-PMMA groups, this difference was not significant. Future cyclical tests may detect such differences.

In a previous study,¹³ researchers used a wider spacer, with a homogeneous width along its length, and applied an initial compressive load for adequate adjustment of the spacer onto the vertebral endplates. This point of contact of the distractor with the bone in a small region of the intervertebral space can be directly related to the results, because during extension, there was displacement of the vertebral body until complete contact of the endplate with the distractor surface. On flexion, this limited point of contact may have acted as a lever, allowing residual motion. Aside from these factors, it is worth noting that it is difficult to find a significant difference that depends on the intervertebral spacer since transvertebral body or transpedicular fixation by itself already leads to a high degree of stiffness.¹³ However, it is possible that over time there will be some degree of subsidence and better adjustment of the spacer into the intervertebral space, allowing for a more homogeneous distribution of the load between the two adjacent segments via the spacer. This may be important in the long term, because the use of a spacer to obtain axial compression via the intervertebral space allows the load to be distributed between the adjacent vertebral endplates, resulting in greater stiffness of the construction; this distribution of load should in theory reduce the stress on the fixation implants, decrease the risk of component failure and improve longevity of the implant.⁴¹

Changes in the adjacent segment have occurred in dogs following cervical vertebral stabilization.^{1,2,10,42} In our study, there was no significant difference between groups when focusing on adjacent segments, that is, vertebral stabilization between C6 and 7 did not lead to an increase in AROM on flexion or extension in the adjacent cranial spaces.

Previously, an increase in AROM on flexion-extension has been observed in the intervertebral space immediately cranial (C4-5) to a stabilized C5-6 intervertebral space when compared with intact vertebral columns.^{30,43} However, there was no significant difference regarding intervertebral spaces C6-7 and C3-4, with a decrease in AROM on flexion-extension in the C3-4 intervertebral space. Therefore, an increase in AROM at the adjacent intervertebral spaces may not occur after vertebral stabilization.^{30,44} A recent study showed that distraction-stabilization of the C5-6 inter-

tebral disk space did not alter intradiscal pressure at the C6-7 intervertebral space.³² In our study, vertebral stabilization was done in a different intervertebral space, and demonstrated different mechanical characteristics in the adjacent cranial intervertebral spaces. No study that investigated the effect of stabilization at C6-7 was found, hindering a more accurate comparison.

Limitations of this study include testing only flexion and extension and absence of cyclical tests. Thus, definitive conclusions regarding clinical application of these techniques and the presence or absence of adjacent segment disease cannot be made. As a pre-clinical study, however, the results provide good evidence to support clinical application. Adjacent segment pathology is a time-dependent phenomenon so little can be learned of its aetiology from quasistatic loading instead of long-term follow-up in real patients.⁴⁵ Despite using a greater number of specimens per group than previous studies,^{12-14,34} larger sample sizes may be needed to avoid type II errors. Having a testing sequence for the samples also makes this a non-randomized study, which may have led to systematic differences between treatment groups. Another limitation of this study is related to the test sequence selected for the groups. The biomechanical tests were performed sequentially, starting with the intact vertebral column, followed by the polyaxial + distractor, polyaxial-distractor and pin-PMMA groups. Analysis of the polyaxial + distractor group before the polyaxial-distractor group may influence results since preparation of the disk and insertion of the interbody distractor may affect the vertebral endplate. However, this sequence was chosen to maintain the same standard of changes in the intervertebral disk space between groups, changing only whether or not the distractor was present. The consequences of preparing the endplate for placement of the interbody distractor in the polyaxial + distractor group were also present in the remaining treated groups, decreasing the difference between them. Despite the changes to the endplates, stabilizing structures such as the lateral and dorsal annulus fibrosus remained intact, mimicking a normal intervertebral disk fenestration.³¹ Another limitation that should be considered is the use of the same specimens in all groups, as previously reported.^{30,33,34} The pins in the pin-PMMA groups were inserted after three holes were created in the vertebral body of each vertebra, which may lead to loosening of the pins if the pin enters the same hole previously created. This, in turn, would affect the final result. Care was taken, however, to avoid any overlap between the perforations, so pins were inserted at locations where there were no previous holes, and macroscopically, there was no overlap at the cis-cortex. Also, the pins were inserted at different angles from the polyaxial screws, being angled laterally and entering the vertebra diagonally. Another factor is that all pins exited the contralateral cortical bone at the dorsal lamina and had their insertion point in the cis-cortex (vertebral body, cancellous bone of the vertebral body, pedicle bone and trans-cortex).

In conclusion, transvertebral body fixation of the C6-7 region with polyaxial screws with or without an interbody distractor was effective and comparable with fixation using

bicortical pins and PMMA. Additionally, we did not observe an increase in the mobility of the cranial VMU. The association of an intervertebral distractor did not add rigidity to the fixation with polyaxial screws and connecting bars.

The studied systems were adequate within the specific study parameters, such as in large dogs, and the findings only apply within the range of forces applied.

Authors' Contributions

P.V.T.M., C.R.A.F., R.C.d.C., C.A.M.P. conceptualized the study. P.V.T.M., C.R.A.F., R.C.d.C., C.A.M.P., A.M.F.R., T.B., F.P. designed the study. P.V.T.M., C.A.M.P., T.B., and F.P. acquired the data. P.V.T.M., C.R.A.F., R.C.d.C., and M.A.F.R. were involved in data analysis and interpretation.

P.V.T.M., C.R.A.F., R.C.d.C., C.A.M.P., A.M.F.R., and T.B. drafted or revised the manuscript.

P.V.T.M., C.R.A.F., R.C.d.C., C.A.M.P., A.M.F.R., T.B., and F.P. approved the manuscript. All authors were publicly accountable for relevant content.

Funding

None.

Conflict of Interest

None declared.

Acknowledgments

The authors would like to thank Dr Célio Jardim dos Santos Júnior and the Hospital Veterinário Cães e Gatos, in Osasco/SP, for kindly allowing the use of their facilities for performing the magnetic resonance scans used in this experiment. Dr Marinho received a doctorate scholarship from the Coordenação de Aperfeiçoamento de Pessoal de Nível Superior (CAPES, Brazil). The authors would also like to thank Dr Marília de Albuquerque Bonelli for her help with translation and editing of the manuscript.

References

- 1 Bruecker KA, Seim HB, Blass CE. Caudal cervical spondylomyelopathy: decompression by linear traction and stabilization with Steinmann pins and polymethyl methacrylate. *J Am Anim Hosp Assoc* 1989;25:677–683
- 2 Dixon BC, Tomlinson JL, Kraus KH. Modified distraction-stabilization technique using an interbody polymethyl methacrylate plug in dogs with caudal cervical spondylomyelopathy. *J Am Vet Med Assoc* 1996;208(01):61–68
- 3 Fitch RB, Kerwin SC, Hosgood G. Caudal cervical intervertebral disk disease in the small dog: role of distraction and stabilization in ventral slot decompression. *J Am Anim Hosp Assoc* 2000;36(01):68–74
- 4 Koehler CL, Stover SM, LeCouteur RA, Schulz KS, Hawkins DA. Effect of a ventral slot procedure and of smooth or positive-profile threaded pins with polymethylmethacrylate fixation on intervertebral biomechanics at treated and adjacent canine cervical vertebral motion units. *Am J Vet Res* 2005;66(04):678–687
- 5 Voss K, Steffen F, Montavon PM. Use of the ComPact UniLock System for ventral stabilization procedures of the cervical spine: a retrospective study. *Vet Comp Orthop Traumatol* 2006;19(01):21–28
- 6 da Costa RC. Cervical spondylomyelopathy (wobbler syndrome) in dogs. *Vet Clin North Am Small Anim Pract* 2010;40(05):881–913
- 7 Corlazzoli D. Bicortical implant insertion in caudal cervical spondylomyelopathy: a computed tomography simulation in affected Doberman Pinschers. *Vet Surg* 2008;37(02):178–185
- 8 Solano MA, Fitzpatrick N, Bertran J. Cervical distraction-stabilization using an intervertebral spacer screw and string-of-pearl (SOP™) plates in 16 dogs with disc-associated wobbler syndrome. *Vet Surg* 2015;44(05):627–641
- 9 Bergman RL, Levine JM, Coates JR, Bahr A, Hettlich BF, Kerwin SC. Cervical spinal locking plate in combination with cortical ring allograft for a one level fusion in dogs with cervical spondylotic myelopathy. *Vet Surg* 2008;37(06):530–536
- 10 Trotter EJ. Cervical spine locking plate fixation for treatment of cervical spondylotic myelopathy in large breed dogs. *Vet Surg* 2009;38(06):705–718
- 11 Agnello KA, Kapatkin AS, Garcia TC, Hayashi K, Welihozkiy AT, Stover SM. Intervertebral biomechanics of locking compression plate monocortical fixation of the canine cervical spine. *Vet Surg* 2010;39(08):991–1000
- 12 Hettlich BF, Allen MJ, Pascetta D, Fosgate GT, Litsky AS. Biomechanical comparison between bicortical pin and monocortical screw/polymethylmethacrylate constructs in the cadaveric canine cervical vertebral column. *Vet Surg* 2013;42(06):693–700
- 13 Hettlich BF, Allen MJ, Glucksman GS, Fosgate GT, Litsky AS. Effect of an intervertebral disk spacer on stiffness after monocortical screw/polymethylmethacrylate fixation in simulated and cadaveric canine cervical vertebral columns. *Vet Surg* 2014;43(08):988–994
- 14 Hettlich BF, Fosgate GT, Litsky AS. Biomechanical comparison of two veterinary locking plates to monocortical screw/polymethylmethacrylate fixation in canine cadaveric cervical vertebral column. *Vet Surg* 2017;46(01):95–102
- 15 Abumi K, Ito M, Sudo H. Reconstruction of the subaxial cervical spine using pedicle screw instrumentation. *Spine* 2012;37(05):E349–E356
- 16 Koktekir E, Toktas ZO, Seker A, Akakin A, Konya D, Kilic T. Anterior transpedicular screw fixation of cervical spine: is it safe? Morphological feasibility, technical properties, and accuracy of manual insertion. *J Neurosurg Spine* 2015;22(06):596–604
- 17 Lewchalermwong P, Suwanna N, Meij BP. Canine vertebral screw and rod fixation system: design and mechanical testing. *Vet Comp Orthop Traumatol* 2018;31(02):95–101
- 18 Meij BP, Suwankong N, Van der Veen AJ, Hazewinkel HA. Biomechanical flexion-extension forces in normal canine lumbosacral cadaver specimens before and after dorsal laminectomy-discectomy and pedicle screw-rod fixation. *Vet Surg* 2007;36(08):742–751
- 19 Smolders LA, Voorhout G, van de Ven R, et al. Pedicle screw-rod fixation of the canine lumbosacral junction. *Vet Surg* 2012;41(06):720–732
- 20 Tellegen AR, Willems N, Tryfonidou MA, Meij BP. Pedicle screw-rod fixation: a feasible treatment for dogs with severe degenerative lumbosacral stenosis. *BMC Vet Res* 2015;11:299
- 21 Zindl C, Allen MJ, Fitzpatrick N, Dufour JS, Litsky AS, Crawford NR. Motion capture analysis of the mechanical performance of a novel pedicle screw-rod fixation system for the canine lumbosacral joint. Paper presented at: World Veterinary Orthopaedic Congress & Veterinary Orthopedic Society Conference; March 1–8, 2014; Breckenridge, CO
- 22 Yahiyo MA. Comprehensive literature review. Pedicle screw fixation devices. *Spine* 1994;19(Suppl 20):2274S–2278S
- 23 Boos N, Webb JK. Pedicle screw fixation in spinal disorders: a European view. *Eur Spine J* 1997;6(01):2–18
- 24 Morgenstern W, Ferguson SJ, Bery S, Orr TE, Nolte LP. Posterior thoracic extrapedicular fixation: a biomechanical study. *Spine* 2003;28(16):1829–1835

- 25 Koller H, Acosta F, Tauber M, et al. Cervical anterior transpedicular screw fixation (ATPS)–part II. Accuracy of manual insertion and pull-out strength of ATPS. *Eur Spine J* 2008;17(04):539–555
- 26 Koller H, Hempfing A, Acosta F, et al. Cervical anterior transpedicular screw fixation. Part I: study on morphological feasibility, indications, and technical prerequisites. *Eur Spine J* 2008;17(04):523–538
- 27 Koller H, Hitzl W, Acosta F, et al. In vitro study of accuracy of cervical pedicle screw insertion using an electronic conductivity device (ATPS part III). *Eur Spine J* 2009;18(09):1300–1313
- 28 Ramos RM, da Costa RC, Oliveira AL, Kodigudla MK, Goel VK. Effects of flexion and extension on the diameter of the caudal cervical vertebral canal in dogs. *Vet Surg* 2015;44(04):459–466
- 29 Ramos RM, da Costa RC, Oliveira AL, Kodigudla MK, Goel VK. Morphological changes of the caudal cervical intervertebral foramina due to flexion-extension and compression-traction movements in the canine cervical vertebral column. *BMC Vet Res* 2015;11:184
- 30 Adamo PF, Kobayashi H, Markel M, Vanderby R Jr. In vitro biomechanical comparison of cervical disk arthroplasty, ventral slot procedure, and smooth pins with polymethylmethacrylate fixation at treated and adjacent canine cervical motion units. *Vet Surg* 2007;36(08):729–741
- 31 Hermann A, Voumard B, Waschk MA, Hettlich BF, Forterre F. In vitro biomechanical comparison of four different ventral surgical procedures on the canine fourth-fifth cervical vertebral motion unit. *Vet Comp Orthop Traumatol* 2018;31(06):413–421
- 32 Knell SC, Park B, Voumard B, Pozzi A. Ex vivo study of the intradiskal pressure in the C6-7 intervertebral disk after experimental destabilization and distraction-fusion of the C5-C6 vertebrae in canine cadaveric specimens. [published online ahead of print, 2021 Dec 1] *Am J Vet Res* 2021;82(12):1003–1012. Doi: 10.2460/ajvr.20.12.0218
- 33 Beishuizen R, Reints Bok TE, Teunissen M, et al. Biomechanical effects of a titanium intervertebral cage as a stand-alone device, and in combination with locking plates in the canine caudal cervical spine. *Vet Surg* 2021;50(05):1087–1097
- 34 Hicks DG, Pitts MJ, Bagley RS, et al. In vitro biomechanical evaluations of screw-bar-polymethylmethacrylate and pin-polymethylmethacrylate internal fixation implants used to stabilize the vertebral motion unit of the fourth and fifth cervical vertebrae in vertebral column specimens from dogs. *Am J Vet Res* 2009;70(06):719–726
- 35 Fuller DA, Kirkpatrick JS, Emery SE, Wilber RG, Davy DT. A kinematic study of the cervical spine before and after segmental arthrodesis. *Spine* 1998;23(15):1649–1656
- 36 Serbino Junior JW, Albuquerque RF, Pereira CA, de Rezende MU, Lasmar RC, Hernandez AJ. Posterolateral anatomical reconstruction restored varus but not rotational stability: a biomechanical study with cadavers. *Knee* 2015;22(06):499–505
- 37 Bayley JC, Yoo JU, Kruger DM, Schlegel J. The role of distraction in improving the space available for the cord in cervical spondylosis. *Spine* 1995;20(07):771–775
- 38 Zankel HT. Photogoniometry; a new method of measurement of range of motion of joints. *Arch Phys Med Rehabil* 1951;32(04):227–228
- 39 Chen SH, Mo Lin R, Chen HH, Tsai KJ. Biomechanical effects of polyaxial pedicle screw fixation on the lumbosacral segments with an anterior interbody cage support. *BMC Musculoskelet Disord* 2007;8:28
- 40 Ferguson SJ, Steffen T. Biomechanics of spinal stabilization. In: Aebi M, Arlet V, Webb JK, eds. *AO Spine Manual, Principles and Techniques*. New York: Thieme; 2007:53–68
- 41 Niu CC, Liao JC, Chen WJ, Chen LH. Outcomes of interbody fusion cages used in 1 and 2-levels anterior cervical discectomy and fusion: titanium cages versus polyetheretherketone (PEEK) cages. *J Spinal Disord Tech* 2010;23(05):310–316
- 42 McKee WM, Pink JJ, Gemmill TJ. Cement plug technique for the management of disc-associated cervical spondylopathy in 52 Doberman Pinscher dogs. *Vet Comp Orthop Traumatol* 2016;29(03):195–201
- 43 Hakozaki T, Ichinohe T, Kanno N, et al. Biomechanical assessment of the effects of vertebral distraction-fusion techniques on the adjacent segment of canine cervical vertebrae. *Am J Vet Res* 2016;77(11):1194–1199
- 44 Zindl C, Fitzpatrick N, Litsky AS, Allen MJ. Kinematics of a novel canine cervical fusion system. *Vet Comp Orthop Traumatol* 2021;34(04):257–267
- 45 Reints Bok TE, Willemsen K, van Rijen MHP, Grinwis GCM, Tryfonidou MA, Meij BP. Instrumented cervical fusion in nine dogs with caudal cervical spondylomyelopathy. *Vet Surg* 2019;48(07):1287–1298