

Hearing Implants in the Era of Digitization



Authors

Heidi Olze, Florian Cornelius Uecker, Sophia Marie Häußler, Steffen Knopke, Agnieszka J. Szczeppek, Stefan Gräbel

Affiliation

Department of Otorhinolaryngology, Campus Virchow;
Department of Otorhinolaryngology, Campus Mitte, Charité
University Medicine of Berlin, Germany

Key words

cochlear implant, remote care, telemedicine, app, big data,
artificial intelligence

Bibliography

DOI <https://doi.org/10.1055/a-0755-2811>

Laryngo-Rhino-Otol 2019; 98: S106–S128

© Georg Thieme Verlag KG Stuttgart · New York

ISSN 0935-8943

Correspondence

Prof. Dr. med. Heidi Olze

Charité University Medicine of Berlin

CVK: Augustenburger Platz 1, D-13353 Berlin

CCM: Charitéplatz 1, D-10117 Berlin

heidi.olze@charite.de

ABSTRACT

The last years' developments could show that the rehabilitation with hearing implants is a field with the highest potential for development and innovation in otorhinolaryngology. New or extended indications were seen with developments of implants, new surgical techniques, and respective rehabilitation strategies.

With the background of limited resources, the increasing number of subjects suffering from hearing disorders, the extended indications and thus the increasing number of CI carriers as well as the need of life-long CI follow-up are one of the major challenges of the future. In order to cope with this situation, com-

pletely new strategies are required beside a close interdisciplinary cooperation and continuous development of the therapy. In this context, digitization of all these processes plays a key role.

This manuscript will describe and discuss the current developments from the perspective of a cochlear implant (CI) providing hospital. The contribution will elucidate manifold digital applications that may be implemented in all phases of CI provision, starting with patient information about the possibilities of hearing screening and preoperative evaluation up to life-long follow-up and clinical research.

The focus is mainly placed on specific applications that play a particular role in the development of digital progress and digital structures in the context of cochlear implantation and that are crucial for understanding the further development.

The options of simplified fitting result for example from automated MAP creation (artificial intelligence); remote care networks (telemedicine, apps) foster the active contribution of the patients themselves and allow completely new types of location-independent healthcare (automated technical implant control, individual settings, upgrades). Central databases may create backups of the current MAP (for example in cases of repair), and document technical data and the hearing performance. Some applications described here, are already implemented in the routine, others are currently being developed. Understanding the possibilities of digitization and their implementation in the context of hearing rehabilitation with hearing implants as well as the recognition of the enormous potential for effective, time-efficient structures is essential in order to use this potential. We as ENT specialists are important protagonists in the healthcare system and beside our high specific expertise we have to meet the requirements of our qualification with regard to digital applications so that we might actively contribute to the success of this process.

Contents

Abstract	106	6. Follow-up – Digitization – CI	121
1. Introduction	108	6.1. What does “CI follow-up” mean?	121
1.1. Hearing disorders: a worldwide health problem	108	6.2. Challenges from the patients’ perspective	121
1.2. Cochlear implants	108	6.3. Challenges from the hospitals’ perspective	121
1.3. Current development and challenges of cochlear implantation	108	6.4. Solutions for CI follow-up	122
1.3.1. Elderly patients	108	6.5. Hearing training in CI follow-up	122
1.3.2. Implantation rate and development	109	6.6. Remote care networks	122
1.3.3. Long-term follow-up	109	6.7. Evidence of telemedical CI follow-up	123
1.3.4. Change of social and professional structures of CI candidates/CI users	109	6.8. Outcome	123
1.3.5. Technical developments and CI users	109	6.9. Perspectives	123
1.3.6. Quality standards, quality management, and data protection	109	7. Innovation Cluster on Interactive Micro-implants (INTAKT)	123
1.3.7. A global problem	109	7.1. Problem description	124
1.4. Focus on digitization and cochlear implantation	110	7.2. Thematic objectives	124
1.5. Summary	110	7.3. Objective, role, and project tasks	124
2. Cochlear Implant and Hearing Screening Under the Aspect of Digitization	110	8. Closing Remarks	125
2.1. Social media and internet presence	110	Acknowledgements	125
2.2. Digitally supported hearing screening	110	References	125
2.3. Screening of children	110		
2.4. Screening of adults	111		
2.5. Screening tools – hearing tests, questionnaires, and apps	111		
2.5.1. Screening tools – big data	112		
2.5.2. Screening tools – limitations and data protection	112		
2.5.3. Screening tools – summary	112		
3. Preoperative Evaluation Prior to Cochlear Implantation	112		
3.1. Digitization in neuroradiological diagnostics	112		
3.2. Planning software “OTOPLAN”	113		
3.3. Digitization in audiology	113		
4. Surgery and Inpatient Stay Under the Aspect of Digitization	114		
4.1. Digitization and cochlear implantation surgery	114		
4.2. Intraoperative imaging	115		
4.3. Intraoperative audiological measurement	115		
5. Digitization in The Context of Cochlear Implant Rehabilitation	116		
5.1. Digitization in the postoperative phase	116		
5.1.1. Basic therapy	117		
5.1.2. Consecutive therapy	117		
5.2. Possible solution – digitization	117		
5.2.1. Digitization in audiological consecutive therapy	117		
5.2.2. Digitalization in hearing therapeutic follow-up	120		
5.2.3. Advantages of digitization for patients regarding daily CI usage	120		
5.2.4. Improvement of bilateral hearing by digital signal processing and control	121		

ABBREVIATIONS

AHL	Asymmetric hearing loss
ASSE	Auditory Speech Sounds Evaluation
AutoART	Auditory response telemetry
AutoNRT	Automatic neural response telemetry
BERA	Brainstem evoked response audiometry
CAP	Compound Action Potential
CBCT	Cone Beam CT
CDS	Clinical decision support
CI	Cochlear Implant
CT	Computed tomography
DPOAE	Distortion product otoacoustic emissions
DVT	Digital volume tomography
eABR	Electrical evoked auditory brainstem response
eCAP	Electrical evoked compound action potential
eSRT	Electrical evoked stapedius reflex test
FOX	Fitting to Outcomes eXpert
HL	Hearing loss
HRQoL	Health-related quality of life
iOs	Mobile Apple operating system
KDD	Knowledge Discovery in Databases
LMIC	Low- and Middle Income Country
MRI	Magnetic resonance imaging
MVBT	Master Volume, Bass, Treble
NFS	Nucleus fitting software
NRT	Neural Response Telemetry
PET	Positron Emission Tomography
PTA	Pure Tone Audiometry
ReHa	Rehabilitation
SOE	Spread of excitation
SSD	Single-sided deafness
TEOAE	Transitory evoked otoacoustic emissions

1. Introduction

Last years' developments led to a rapid boom in the whole area of hearing implants that are a field with highest innovation potential in otorhinolaryngology. Developments of implants, new surgery techniques, and respective rehabilitation strategies were accompanied by new or extended indications. The variety of possible implantations is a new, highly exciting challenge for us as ENT specialists. In order to manage and frame this complex process, completely new strategies are required beside a close interdisciplinary cooperation and continuous development of therapies.

The increasing digitization of social life also changes the requirements to modern healthcare provision and further it offers chances for a more efficient healthcare system.

The digital revolution represents great challenges to all parties. But on the other hand, it also opens new options, for example in the field of hearing rehabilitation which will be dealt with in this article. Understanding the possibilities of digitization and implementing them in hearing rehabilitation with hearing implants as well as acknowledging the enormous potential for effective, time-efficient structures is essential in order to be able to use this potential and to actively contribute to this process.

1.1. Hearing disorders: a worldwide health problem

According to recent data of the WHO, more than 5% of the population – or 466 million individuals – are affected by hearing disorders worldwide (432 million adults and 34 million children). It can be expected that in 2050 more than 900 million people will have to face the problem of hearing disorder, which would be one in ten (adult HL > 40 dB; pediatric HL > 30 dB, in the better hearing ear). Most affected individuals are found in so-called “low and middle income countries”.

Untreated impaired hearing is associated with significant socio-economic charge and costs, amounting to 750 billion US\$ per year, according to the WHO [1].

For the patients, it often means a significant impairment regarding communication and social interactions. Hearing disorders have a significantly negative impact on the quality of life, and especially in older patients, they may cause emotions of loneliness, social isolation, and even symptoms of depression [2–7].

Prevention, diagnostics, and therapy of hearing disorders is not only of global interest from the cost-effective aspect, but the affected individuals have a great benefit beyond improved auditory abilities with regard to manifold psychological and psychosocial areas and to a sustainable improvement of the quality of life [8–12].

Depending on the type and severity of the hearing disorder, various therapy options may be discussed for hearing rehabilitation. As ENT specialists in Germany, a country with highest standards of healthcare provision, we find ourselves in a very privileged position that we cannot only inform our patients extensively, but also offer them all options of modern therapy of hearing disorders. The spectrum encompasses hearing improving surgery via provision of hearing aids up to different options for hearing implants.

1.2. Cochlear implants

The provision with electronic inner ear prostheses (cochlear implant, CI) for high-grade hearing impaired or deaf patients which represents an enormous progress in the treatment of affected in-

dividuals. This allows many patients to benefit from hearing and speech rehabilitation and in case of pediatric patients to learn the language (habilitation) [13].

The success story of cochlear implants, an auditory neuro-prosthesis, has already been told many times [14]. Generally, postlingually deafened patients achieve an open speech understanding and may even answer phone calls. In children, a nearly regular speech development can be achieved if the implantation is performed early after onset of deafness [15].

Due to the rapid technical development combined with improved atraumatic surgery methods and modified rehabilitation strategies leading to excellent results, implantation could be established as standard therapy for sensory hearing loss.

Own investigations revealed the gain in speech understanding and quality of life (HRQoL) as well as reduction of stress and tinnitus burden up to improved psychological comorbidities in different age clusters [5–7, 10–12, 16].

Overall, the cochlear implant may be considered as prototype for replacing the auditory sense. Currently, about 300,000 patients worldwide are cochlear-implanted [17].

1.3. Current development and challenges of cochlear implantation

The implantation of patients with severe hearing loss is a complex process requiring interdisciplinary cooperation of various disciplines. Furthermore, the therapy is continuously being developed so that the acquisition of information and teaching of most current knowledge is essential [13].

Hence, the developments of the last 15 years led to a rapid boom in the whole field of hearing implants.

The complexity and variability of possible implantations presents enormous challenges to the specific expertise of the cochlear implanting hospitals.

Basically, cochlear implantation is suitable for patients in whom it seems to be possible to achieve better hearing and speech understanding with CI compared to common hearing aids [13]. In order to allow binaural hearing, it is also necessary to find an optimal therapy option for each ear.

So today, beside bilateral sensory hearing loss and deafness in children and adults, the indications are also single-sided deafness (SSD) and asymmetric hearing loss (AHL) as well as high-frequency hearing loss. Not only an importantly increasing number of possible CI candidates result from these new or extended indications, but also manifold variations appear reaching from binaural CI via CI and hearing aid, CI combined with other implants such as Vibrant Soundbridge or Bonebridge up to CI with normal hearing on the other side.

The extended spectrum of indications in combination with the variability of hearing systems presents important requirements to the qualification and the expertise of all parties contributing to the entire rehabilitation process.

1.3.1. Elderly patients

Another aspect is the increasing percentage of older patients who receive CI today. While in our hospital the first patient beyond the age of 70 was cochlear-implanted only in 2006, the percentage

today amounts to 25 % of all adult patients receiving CI (own data from 2012–2017). This tendency will certainly continue.

Based on surveys of the German Federal Statistical Office, about 22 million people in Germany were older than 65 years in 2011 [18]. Because of the progressing socio-demographic change observed in Europe, the percentage of older subjects in our society is expected to increase significantly. With an incidence of about 2/3 of people older than 70 years, hearing disorders are meanwhile considered as wide-spread diseases [2].

Based on the German guideline on cochlear implantation and central auditory implants [19], there is no age limit for CI; and also our own study results show that cochlear implantation may be a very successful therapeutic option for hearing rehabilitation of patients who are older than 70 and even 80 years. Older patients do not only benefit from an improved HRQoL, but also with regard to their cognitive abilities [5–7, 20].

1.3.2. Implantation rate and development

Despite the important growth rates per year of cochlear-implanted patients in Germany, the significance of necessary information and consultation has to be emphasized with regard to the worldwide low implantation rate of hearing impaired or not adequately treated patients. According to estimations of the WHO, the prevalence of severe hearing loss (61–80 dB) and the hearing impairment of more than 80 dB in adults amounts to nearly 1 % worldwide [21].

In Germany, the percentage of patients having received cochlear implants amounts to less than 10 % with regard to the group of patients with CI indication [22–24]. Currently, only in Germany about 1 million candidates would be suitable for cochlear implantation, actually about 50,000 have received CI [15].

With only 6 % of the patients having a CI indication, the implantation rate in the USA is similarly low [25]. Overall, worldwide only about 300,000 CI had been implanted up to now [17].

1.3.3. Long-term follow-up

With increasing numbers of patients and further expected extension of the indication spectrum for CI, the problems regarding implantation need versus resources will increase even more. The implanting institutions will have to continue bearing the responsibility for the patients' entire rehabilitation process. This process starts with the preoperative care and information, continues with implantation and postoperative basic and subsequent therapy, and ends up with life-long follow-up [13].

1.3.4. Change of social and professional structures of CI candidates/CI users

The percentage of implanted patients, who are very well integrated in professional and social everyday life, increases also as a consequence of the extended spectrum of CI indications (e. g. SSD).

Especially these patients wish to have appointments for follow-up examinations that are compatible with their professional or family-related situation. Ideally, the follow-up should be integrated in their daily life.

In this context, furthermore longer journeys from areas with low population density and only few rehabilitation sites represent a problem when the respective institution has to be reached.

1.3.5. Technical developments and CI users

The large variety of possible implantations is accompanied by an extended portfolio of implants, electrodes, and speech processors. Also the field of technical accessories presents enormous options and manifold innovations. The patients' desire and the physicians' aspiration consist of managing as many as possible complex hearing situations in an always better way. For this purpose, technical accessories are sometimes needed that make handling of the CI system more complex and thus more difficult especially for older patients.

1.3.6. Quality standards, quality management, and data protection

The efforts of all parties involved in the rehabilitation process aim at increasing the quality of cochlear implantation. According to the German guideline, cochlear implantation requires an interdisciplinary team and a quality-managed concept that reaches from indication up to life-long follow-up and that is written down in the German AWMF guideline on cochlear implantation [19].

In addition, the white paper on CI lists the scope of the measures on supplementary quality assurance of cochlear implanting institutions [13]. Beside the annual descriptions and assessment of organizational, structural, diagnostic, and therapeutic standard processes in a quality management system (including manual), also the implementation of these processes in a quality management certification procedure is mentioned.

Additionally, a continuous survey of the CI registry datasets should be performed because quality assurance in the field of cochlear implantation obligatorily requires the assessment of implant-related data considering the applicable laws of data protection. Also these measures, including the requirements of data protection, bind time- and staff-related resources.

1.3.7. A global problem

Hearing disorders are a global health-related problem. Worldwide cochlear implants are implanted, increasingly also in LMICs where the follow-up is insufficiently organized. Also in this context, there is a high need of future-oriented concepts that meet these conditions.

In summary, the mentioned developments, i. e.

- Care for increasing numbers of patients with at the same time identical staffing conditions
- Care for older patients with increased need for treatment and comorbidities
- Extended spectrum of indications and variability of hearing systems
- Requirements to qualification and education
- Changed social and professional structure of the patients
- Necessity of life-long follow-up that does not necessarily have to take place in highly-specialized institutions for all CI users
- Observation of quality standards, quality management, and data protection represent an enormous challenge with regard to always decreasing staffing and financial resources (need versus resources).

This starting position forces all parties that are involved in the organizations, structural, diagnostic, and therapeutic processes to perform effective innovations in the context of hearing rehabilitation with CI and other hearing implants.

1.4. Focus on digitization and cochlear implantation

The efforts of all parties contributing to the rehabilitation process aim at increasing the quality of cochlear implantation with at the same time increasing efficiency of the resources deployed.

Hereby, digitization of all these processes plays a key role. The WHO defines e-health as the application of information and communication technologies (ICT) in healthcare systems, for example in research, teaching, medical diagnostics, or also treatment. The possibilities to implement ICT are manifold.

Already today, many patients retrieve online information prior to medical consultation, with rising tendency. This makes clear that more and more patients wish an active empowerment. Telemedicine and medical apps allow achieving this wish.

The options of simplified fitting (MAP creation) result for example from (semi-) automated MAP creation (e. g. NFS, FOX, or other artificial intelligence applications).

Due to online connection (telemedicine, remote care, and apps), services for CI users close to their home seem to be easier to realize. Also in the context of cochlear implantation, telemedical remote care concepts allow completely new options of care with active involvement of the patients such as automated technical implant control, programming, and technological upgrades. Furthermore, central databases may save the current MAP for example in cases of repair, technical data and the hearing performance may be documented.

1.5. Summary

Some of the above-mentioned applications are already implemented in daily life, others are currently being developed. Data storage in central databases as well as networking is common in many areas of daily life. Regarding the care for CI patients, such solutions are currently developed or even already implemented, as for example networking of implanting hospitals with follow-up institutions.

Due to the high number of cochlear-implanted patients and the standardized process structure and quality of cochlear implantation clearly defined by the German guideline and the white paper, this article describes and discusses the current developments from the perspective of a cochlear implanting hospital.

This process encompasses the stages of preoperative evaluation and information/consultation, surgery (implantation) up to post-operative basic and subsequent therapy, and ends up with the life-long follow-up provided by the implanting institution. With regard to the mentioned implantation rate, also the fields of information and screening are important for potential candidates.

Hereby, specific applications are elucidated in a much targeted way that play a key role in the development of digital progress and digital structures in the context of cochlear implantation and that are important for understanding the further development.

Regarding the rapid changes, i. e. so-called digital revolution, this review article can only be a snapshot of a rapidly developing area – with no claim to completeness.

2. Cochlear Implant and Hearing Screening Under the Aspect of Digitization

As already mentioned in the introduction, expected extensions of the formerly very strict CI indications will lead to increased health-

care service obligations so that the necessity of sufficient screening procedures especially for CI candidates will significantly gain in importance. With the approach of nation-wide identification of CI patients, digital solutions are required due to the data quantity and at the same time limited resources.

2.1. Social media and internet presence

Independently from the age, the exchange in social media is meanwhile an implemented tool in our societies. In particular hearing impaired subject benefit from this medium which allows them, beside mere online researches, contacting others and retrieving information. Of course, the industry has already recognized this tendency and provides channels and blogs around the topic of cochlear implants because a high number of pre-selected candidates or “followers” can be reached with only few clicks. The internet presentations of the four most important cochlear implant manufacturers are very professionally designed [26–29].

Aiello et al. [30] examined the impact of social networks on the stress level of parents with children who were born deaf with potential cochlear implantation. The authors could not reveal any difference in the stress levels compared to an online questionnaire inventory of both investigated groups with and without access to specific social networks for concerned people. According to an analysis of English-speaking websites with the content of hearing loss and its treatment with cochlear implants, 64% of the available sites are commercial [30]. Only a small percentage of these sites met score-based, comparable quality criteria.

The multi-language offer of the Ida Institute [31] is highly interesting, which is an independent non-profit organization that focuses on the personalized care for people suffering from hearing disorders. The Ida Community helps patients to better describe their impairments and to contribute actively to their treatment. It also allows treating physicians to better understand the individual hearing disorder of the patient. Interestingly, mainly older hearing impaired subjects use the online platforms more frequently than normally hearing peers [32].

Consequently, also e-services up to online availability of physicians and remote care are required. This is particularly important with regard to pre-medical consultation and screening examinations. Already because of the quantity of questions and the data volume that is generated hereby, digital solutions seem to be desirable. Finally, also due to the worldwide rather low implantation rate of hearing impaired or not adequately treated individuals, the significance of the necessary consultations must be emphasized.

2.2. Digitally supported hearing screening

In order to meet the requirements of patients, who have the indication of cochlear implantation, and those of the even larger group of subjects who want to know if CI is possible, digital solutions are required. The primary objective remains the overall identification of CI candidates because the evaluation process of implant candidates has significantly increased regarding its quantity and complexity.

2.3. Screening of children

Patient groups that should be included in this digitally supported evaluation process, are newborns and small children prior to language acquisition and on the other hand the large group of adults.

By introducing the newborn hearing screening based on a decision of the German Federal Joint Committee dated January 1, 2009, a nationwide primary screening was established in Germany. The examinations and also the tracking of the pediatric patients with consecutive follow-up examinations aim at preponing the time of diagnostics into the first year of life. In this context, uni- or bilateral hearing impairments as of 35 dB in the main speech area are considered as significant. This early detection is associated with preponing the time of treatment – either by prescribing hearing aids or rehabilitation by means of CI. Finally, the improvements of the surgery techniques as well as the perioperative setting could relativize the parents' fears with regard to an early implantation [33].

Digitization will play a key role for tracking and for necessary follow-up examinations. In this context, medical apps might remind parents, but also answer arising questions and clarify certain circumstances. Another option might be the telemedical consultation of concerned parents.

In summary, the last years could show that children with CI indication are identified very early. In Germany, the rate of newly implantable children will stagnate while the total number of CI patients will be further growing because more and more older patients will be treated with CI.

2.4. Screening of adults

Adults with a sudden uni- or bilateral hearing impairment, for example in the context of sudden hearing loss event, specific inflammation, or traumatic origin, and the continuously growing group of adult patients with progressive bilateral hearing impairment up to deafness in the course of presbycusis need thorough and reliable diagnostics of their hearing disorder.

Already in the subgroup of patients suffering from presbycusis, the number of possible CI candidates is growing who can no longer participate adequately in daily life with hearing aids alone.

The usual way of poorly supplied patients is directly via the ENT specialist (a) or previously via the general practitioner (b).

A growing market is the consultation of patients by hearing care professionals and hearing aid providers and by manufacturers of medical products up to worldwide active CI companies (c). Meanwhile they are prone to cooperate, and also cooperation between the groups (a) and (b) can be found.

Other important first contacts are the health insurance companies (d). Already today, the insured subjects are courted to choose the direct digital pathway for consultation in cases of particular questions in order to receive “smart solution” via digital and safe channels. Consultations via phone calls or apps seem to be an alternative to personal visits in practices in many cases.

Another field that must not be neglected is self-consultation (e) by means of conventional media and in particular by means of digital information with the keyword of active empowerment. The bases of reliable digital sources are mainly the groups (a), (d), and in particular (c) [26–29].

It seems to be clear that the single groups focus on different aspects with regard to the information, depending on socio-economic backgrounds. It is desired that the information and consultation are scientifically sound and evidence-based also in the digital sector and focus on the patients' benefit and well-being.

Also in the future, the final consultation and information of the CI candidates will be performed by the treating institution or hospital. With regard to expected increasing referral rates [34–36] after information on the pathways (a)-(e) it seems to be useful to identify patients with an indication of surgical treatment by means of screening.

2.5. Screening tools – hearing tests, questionnaires, and apps

Adequate tools will be hearing tests that are available online or sent electronically in combination with questionnaires. Both screening tools are already available today and are more and more applied (groups (c) and (d)). Sending pure tone audiograms (PTA) to the service-providing hospital does not seem to be an appropriate solution since patients with inadequate speech understanding are often insufficiently assessed. It appears to be more suitable to additionally measure the hearing ability via speech recognition in noise, e. g. as digit-triplet test [37]. This screening procedure assesses how speech can be understood in noise.

Another option is the combination of PTA with understanding of monosyllables [24]. The resulting classifications correlate well with clinical experiences of more extended investigations. In this context, the article published by the team around Ulrich Hoppe from Erlangen, Germany, seems to be of particular interest [38]: 318 ears of CI candidates were evaluated retrospectively with regard to their real treatment. After classification into the categories of I) introduction of specialized CI pre-diagnostics versus II) continuation or optimization of hearing aid use, the previous cochlear implantation and the postoperative speech recognition were further evaluated. From 96 cases classified as CI candidates 34 (35%) received CI after completion of the preoperative diagnostics. Among the cases classified as candidates for hearing aids in the screening, only 4 patients (2%) received CI so that the authors correctly state a sufficiently specific screening procedure.

It is rather difficult to overlook the enormous number of available healthcare apps for android and iOS, among those “hearing test apps”, “otoscope apps”, but also “hearing training apps” and others are found. In a review on the assessment of the hearing ability, Bright and Pallawela found 11 trials on 6 different apps [39]. The authors of the study conclude a high variance of the results with fluctuating sensitivity. The application of “hearing test apps” to substitute the gold standard of pure tone audiometry is not recommended by the authors of the review. The main problem of such apps is the missing calibration, which could be shown by Le Prell and co-workers [40]. Depending on the level, higher values of 5–10 dB were measured compared to a calibrated audiometer. Nonetheless, these apps are useful for orienting measurements in order to identify occult hearing disorders and to reveal the necessity of treatment for the patient [32]. Due to the low costs, the portability, and the simple access, such apps may be useful for screening for example in countries with insufficient medical service provision.

The accuracy of questionnaires that are assessed with adults correlates satisfactorily with the result of complex CI pre-diagnostics. It is obvious that in our world with time and resource limits no CI candidate wants to pass the complete process of the Charité test battery [7, 8, 41] online – this will be reserved to single internation-

al centers, but subjective questionnaires on speech recognition [35, 42] and questionnaires on cognitive abilities [36, 43] may be assessed without any problem.

Furthermore, passive monitoring via app, but also data acquisition via wearables may provide insight about the hearing ability without the need that the user has to actively invest time, e. g. by recording the situation when the user can no longer follow conversations due to acoustic reasons or by documenting in which hearing situation the user repeatedly increases the volume of the device.

2.5.1. Screening tools – big data

With regard to the compatibility of current and future device generations and their degree of networking (internet of things), these parameters may be implemented based on algorithms in the arising data flood. Regarding the topic of big data, 2 of the 5 big V seem to be important for CI screening: the problem of the “volume”, i. e. each user produces an enormous data quantity, and the “variety”, i. e. the multitude of gained data types. Both can no longer be analyzed by current methods.

As side effect, terminal devices such as smartphones may adapt to the individual hearing situation based on the retrieved data. This may occur by techniques on signal improvement such as signal compression and frequency-related amplification in order to adapt the quality of the signals and to reduce the hearing effort under unfavorable hearing conditions. Beside the primary benefit of the user due to the improved hearing situation, additional data are collected that depict the hearing behavior in the course and thus show when CI screening might be appropriate. The prognosis that a smart terminal device will then directly order a CI (in analogy to smart refrigerators) does not seem to be realistic in the near future.

It might also be attractive to weigh the users' moods. Assessment and documentation (active and passive) already take place today and these data are economically used. In this way, the CI candidates' suffering could be determined: it remains unsatisfactory and uneconomic if a patient is correctly identified as CI candidate by means of a highly specialized screening procedure, but then no relevant treatment desire is expressed in the healthcare providing institution.

2.5.2. Screening tools – limitations and data protection

One weakness of these web-based screenings must be emphasized, which is the differentiation between merely sensorineural hearing impairments and conductive hearing loss. For an ENT specialist, the diagnoses of cerumen obturans, for example, and many other diseases that lead to relevant conductive hearing loss are easy to make. Thus, only after verification of the web-based suspected diagnosis that CI might be indicated further necessary steps such as imaging should be undertaken – in particular from the point of view of radiation protection as well as socio-economic aspects.

Regarding safety and data protection in Germany – which are defined by the data protection law, the telecommunication law, and the telemedia law – it will be a great challenge to ensure that the individual users always keep full control of their data. Already today, this aspect becomes apparent with the growing market of fitness apps, medical care providers, and social media apps with healthcare relation. The current developments in the area of tele-

medicine and apps show that digitization in the medical sector booms rapidly.

In this way, patient data are always and everywhere available via smartphone apps, but it must be questioned if the individual patient or the general practitioner will be in a position to manage these data adequately or who will assume this “big data” task.

2.5.3. Screening tools – summary

The digital revolution represents an enormous challenge for all parties such as patients, physicians, or business companies. But on the other hand it offers many chances, for example in the context of CI screening – that have to be taken.

3. Preoperative Evaluation Prior to Cochlear Implantation

The preoperative evaluation and diagnostics prior to cochlear implantation (CI) encompasses ENT-specific history taking and clinical examination, in particular ear microscopy. In addition, audiometric measurements (pure tone audiometry, speech audiometry, assessment of monosyllabic understanding, sentence tests, verification of hearing aids) and objective hearing tests (tympanometry, TEOAE/DPOAE, click BERA). Furthermore, vestibular tests are performed as well as neuroradiological diagnostics by radiologists.

In the context of cochlear implant diagnostics, digitization plays a key role in the field of clinical examination, imaging, and audiology.

3.1. Digitization in neuroradiological diagnostics

One aspect of digitization in CI diagnostics is the digitization in neuroradiological diagnostics. On one hand, a digital correlation of clinical patient data and diagnoses with imaging shall take place in order to create algorithms on digital findings by means of artificial intelligence. On the other hand, a central cross-linking of data between hospitals and practices may occur and centrally stored by means of big data (► Fig. 1). For treating physicians this facilitates the access to image files created in other institutions, facilitates diagnosis and further treatment of the patients, and avoids overstraining the capacities of the department of radiology and thus additional expenses. In this way, even the radiation exposure of the patients due to unnecessary imaging (CT scans, X rays) may be reduced [44, 45].

To avoid over-diagnostics, in the early 2000ies the clinical decision support (CDS) system was developed in the USA that was intended to ensure a possibly reasonable application of different imaging procedures [46, 47]. Hence, referring physicians apply this CDS system before indicating CT scan, MRI, and PET-CT which give evidence-based recommendations on imaging. This procedure was confirmed by President Obama in the “Protecting Access to Medicare Act of 2014” and it is currently applied in all US states [45]. In Germany, this standardized procedure is not yet fully implemented as support for decision making of radiologists.

One future development in the area of digitization in imaging diagnostics is the individual care for patients and assessment of findings based on a real-time analysis of radiological images by big data techniques. Hereby, patient and imaging data are correlated and evaluated with data from clinical trials, medical journals, and medical databases [47].

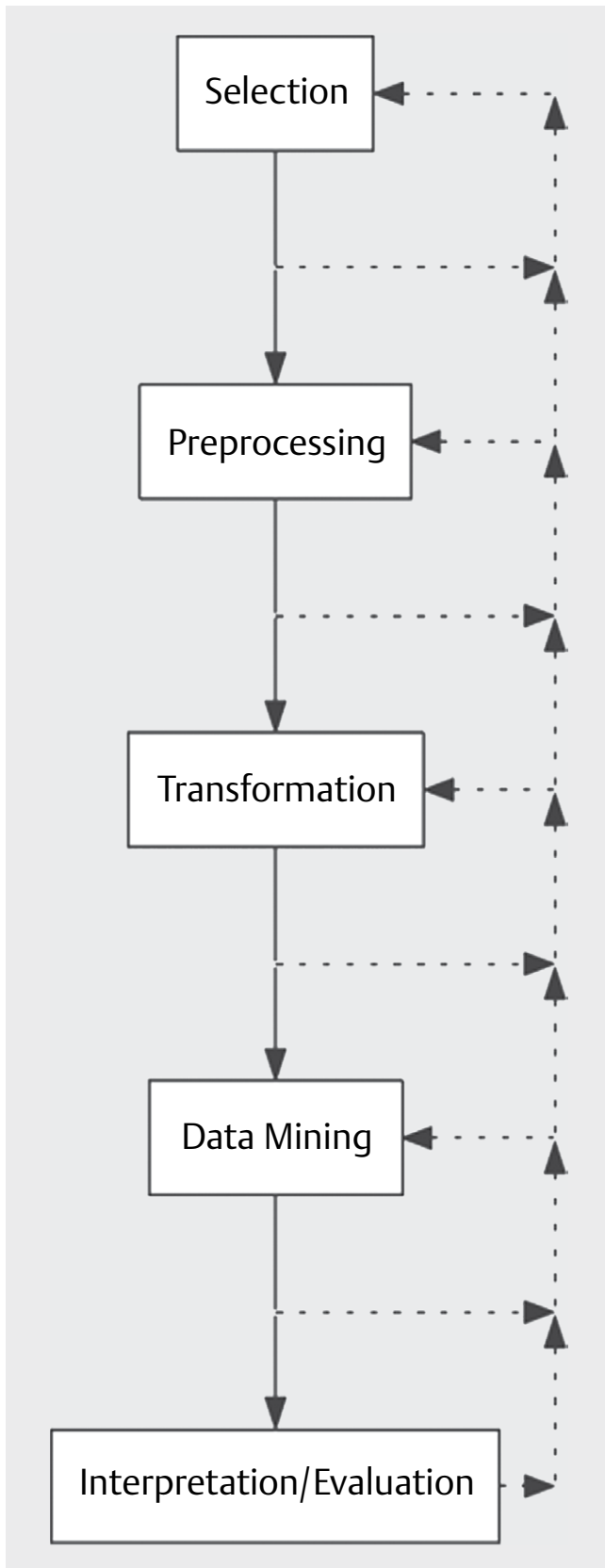

► **Fig. 1** Big data in audiology. Selection = data selection; preprocessing = data cleansing; transformation = data transformation into a suitable form; data mining = classification and categorization of data; interpretation = data interpretation [50].

In the context of CI diagnostics, such a big data correlation of radiological imaging may reveal interesting comparative findings, especially in cases of complex inner and middle ear malformations. So when planning CI surgery the individual anatomical conditions of the patients may be taken into account.

3.2. Planning software “OTOPLAN”

An innovation in the context of preoperative imaging for CI is the software called OTOPLAN. It allows evaluating neuroradiological images (CT scans, MRI, CBT) with new tablet-based planning software; the cochlear may be accurately measured and in this way the length of the CI electrode is individually adapted to the patient. The OTOPLAN software was developed by MedEL and Cascination companies (► **Fig. 2**). This planning software serves for generating 3D reconstructions of the temporal bone by means of computed tomography or cone beam CT (CBCT). They are adapted to the individual anatomy of the patient and thus allow a precise preoperative view of the surgery site and structures at risk such as the facial nerve.

Another innovative application of this software is the measurement of the cochlear and thus planning the optimal length of the CI electrode. Such a personalized planning of cochlear surgery leads to a possibly atraumatic implantation and allows expecting a post-operative improvement of the hearing rehabilitation. Gerber et al. [48] were the first who applied the planning tool in an experimental study with cadavers for robotic, minimally invasive hearing implant surgery. Hereby, surgery could be successfully planned with the software in all cases. Another trial published by Ping et al. [49] confirmed the mentioned positive results of the planning tool. By means of the software, the facial nerve was highlighted on the CBCT images in its course through the temporal bone in order to protect it during surgery.

Further trials on clinical application of the software tool OTOPLAN are currently not available.

3.3. Digitization in audiology

Not only in the radiological, but also in the audiological sector central linkage of patient data is reasonable and possible, as published by Mellor et al. [50]. “Data mining” describes the process how knowledge is extracted from large data volumes and correlated practically and reasonably. This also allows rapid filtering and evaluation of data. ► **Fig. 1** summarizes the process called Knowledge Discovery in Databases process (KDD).

In the field of audiology, data mining tools are also useful. Cox et al. [51] were the first who presented them at the occasion of the International Conference on Computational Intelligence in 2004. From 180,000 individual audiological findings assessed in 23,000 patients, heterogenic data such as audiograms, demographic data and reports were used and evaluated by means of statistical and neural techniques. This project was part of the national “Modernising Hearing Aid Services” initiative of the UK. In the future, such a national initiative would also be desirable in the area of cochlear implantation.

Another important aspect in the field of audiology concerns the centralization of data which is already realized in many hospitals and ENT practices in England and Scandinavian countries by the databases of “AuditBase” from Auditdata company (auditdata.com). This database contains information on the patient, audiometric

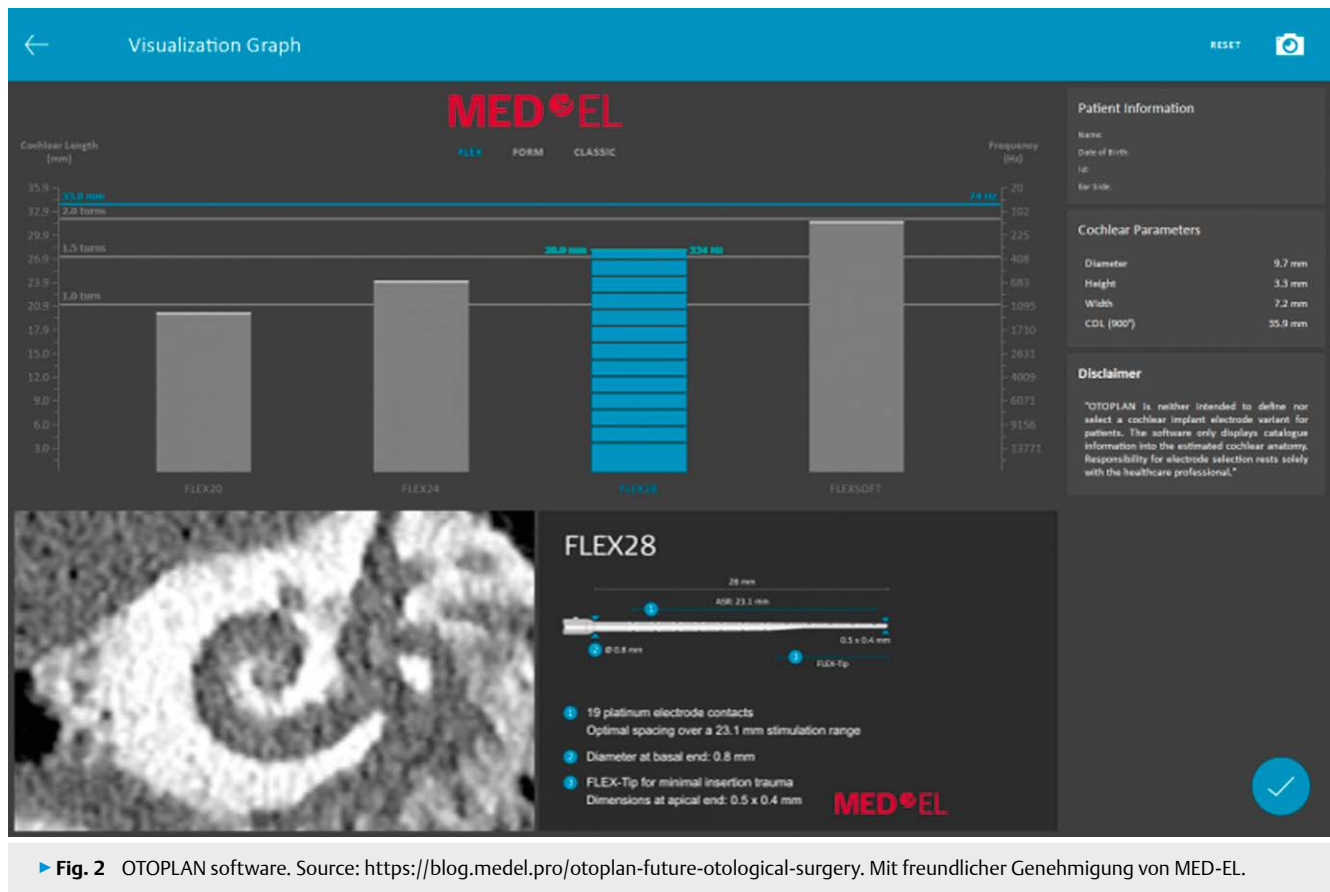

measurements, the implant of CI patients, and the hearing aid in hearing aid patients as well as on hearing rehabilitation.

As outlook for CI patients, linkage of audiological data as well as a standardized database is possible and feasible in the future. Audiometric data may be stored in a standardized way and retrieved during consultation, surgery, and in ENT practices.

Data on the implant may also be stored in the database and the assessed data may be forwarded to rehabilitation institutions. Thus, also the feedback from the rehabilitation institution to the surgeons and physicians in hospitals and practices would be easily possible.

Another promising development is a cochlear implant diagnostics app, similar to the already existing "iHealth" app. Hereby, the patients may store all their data assessed during diagnostics (clinical findings, audiometry, hearing nerve/PromTest, vestibular tests, CT scans, MRI). This topic will be further elucidated in the chapter on hearing rehabilitation.

4. Surgery and Inpatient Stay Under the Aspect of Digitization

4.1. Digitization and cochlear implantation surgery

One objective of intraoperative imaging is the dynamic linking of different components in the operating room. This topic is discussed by another author of this book. In this chapter, however, the intraoperative digitization in cochlear implant surgery will be described in detail.

In this context, the dynamic networking of computer-controlled devices and invasive tools such as drill and cutting instruments is of major importance. This linkage serves for avoiding errors and optimizing the process. Furthermore, the efficiency of the processes is improved and the duration of surgery is reduced, which leads to lower consumption of resources and an increased patient safety.

In the operating room, also the "interoperability" should be fostered, which means that the surgeon and his team as well as the anesthesiologist and his team may display the same patient data on their screens in a centralized and summarized way. Further innovations that are relevant for the surgeon are the sterile control of different tools such as for example navigation and surgery table that are displayed on a central screen. Another helpful innovation is the linkage of imaging material such as CT scans or MRIs with the surgery microscope so that the screen of the microscope may show the preoperative images [52–54].

The central digitized patient record where surgical and anesthesiological data as well as preoperative diagnostics are included facilitates the later creation of reports and data evaluations with regard to complications and avoidance of errors.

This networking process in the operating room is tested and investigated at the University of Leipzig, Germany, in the Innovation Center Computer-Assisted Surgery (ICCAS) in a model OR. Beforehand, the same objective had been pursued by the project entitled OR.NET of the University of Aachen, Germany [52–54]. The projects were and are supported by the Federal Ministry for Education and Research.

One innovation in the field of intraoperative digitization of cochlear implantation is robotic CI surgery that was described by Klenzner et al. [55] in 2009 and that was also presented later in a clinical trial by Caversaccio et al. [56]. A system for robotic cochlear implant surgery was developed and successfully applied in one patient. For this intervention, the access to the cochlea is drilled by the robotic system via posterior tympanotomy. This method is still very time-consuming with a duration of about 3 h for surgery [56]; however, it bears the potential to reduce the duration of surgery in the future. Furthermore, the effectiveness, safety, and feasibility of this method could be confirmed in this trial. In the future, advantages of this method might be an individual planning of the cochlear access as well as a more careful and thorough insertion of the electrode and an accurate positioning of the electrode in the cochlea.

4.2. Intraoperative imaging

In the context of cochlear implantation surgery, intraoperative imaging is a useful innovation, especially in cases of complex anatomical circumstances and malformations of the inner ear. Cosetti et al. [57] reported about intraoperative imaging by means of x-rays according to Stenvers. In few cases, a tip rollover or the extracochlear position of the electrode could be detected by intraoperative imaging. In their study, Vittaro et al. [58] also describe the detection of a wrong position of the electrode by means of intraoperative x-ray. In many hospitals, the intraoperative x-ray image is replaced by C arm fluoroscopy [59, 60], which allows making 3D radiological images of the electrode position with low radiation exposure after electrode insertion during cochlear implantation. In addition, cone beam CT or cone beam tomography with image amplification or flat panel detectors is applied during and after surgery for control of the CI electrode position [61]. In current trials, intraoperative CT imaging was mainly used in cases of malformations of the inner ear and anatomical particularities such as an aberrant course of the facial nerve [62–64]. In a case series, Yuan et al. [63] describe intraoperative CT imaging in 10 patients. The wrong position of the electrode in two patients could be detected by means of CT scan and corrected during surgery. Stelter et al. [64] report about the successful intraoperative CT scan and application of the navigation by means of BrainLAB for CI electrode insertion in a patient with posttraumatic sensorineural hearing loss.

While postoperative imaging for control of the electrode position is the gold standard, imaging during CI surgery is desirable, however, it will not be available in many hospitals in the future because of the expenses and the limited applicability for example of CBT in the OR and thus insufficient device utilization. Hence, it is desirable to diagnose the possibly wrong position of an electrode by means of audiological measurement methods instead of depending from intraoperative imaging.

4.3. Intraoperative audiological measurement

Audiological quality control during cochlear implant surgery is performed by means of three measurement methods that are usually done by an audiologist in the OR.

The impedances of the intracochlear electrodes are determined by means of telemetry. In addition, the compound action potential of the hearing nerve is measured (electrically evoked compound

action potential, eCAP) in order to verify the response of the hearing nerve on electrical stimulation. The stapedius reflex is measured by means of electrical stimulation (electrically evoked stapedius reflex test, eSRT).

These measurement procedures may also be performed by remote telemetry, i. e. the audiologist is not in the OR, but at a workplace with a computer connected to the OR (webcam and loudspeaker). Such a procedure was first described by Shapiro et al. in 2008 [65]. Yanov et al. [66] compared this procedure to the classic procedure in a current prospective randomized trial. In the context of remote telemetrical measurement, computers with network access in the OR and at the workplace of the audiologist are needed as well as a visual-auditory system (webcam and loudspeaker) in addition to the standard equipment. Correct measurements by the remote network connection could be confirmed that did not significantly differ from the classic measurement method in the OR. Furthermore, significant time savings due to the telemetrical procedure could be revealed (10.04 vs. 18.64 minutes).

Measurement of the eCAP may also be performed automatically as automated neural response telemetry (AutoNRT) or AutoART (auditory response telemetry). The technology of AutoNRT was first described by Botros et al. [67] and van Dijk et al. [68] reported about the clinical applicability. The Nucleus Cochlear Implant system (Cochlear Limited, Australia) or the Maestro system (MedEL, Innsbruck, Austria) may automatically determine the thresholds triggering the stimulation response of the hearing nerve by means of an algorithm that is based on machine learning technique and decision tree analysis [69]. Tavartkiladze et al. report about reliable results with the AutoNRT technology compared to manual NRT measurement. In addition, the AutoNRT measurement takes significantly less time. One negative aspect of this measurement method is the limited applicability because not all patients are suitable for this measurement method. In AutoNRT, the pulse width cannot be modified and so the measurement has to be repeated manually in cases of negative stimulus response, and the pulse width has to be extended, if needed.

In order to detect a wrong position of the electrode, Grolman et al. [70] measured intraoperatively the extension of the neural excitation (so-called “spread of excitation”, SOE). In this trial, the measurement and intraoperative CBT were performed in 72 cochlear implant surgeries. In 4 cases, the electrode had been wrongly positioned which the experienced audiologist could detect based on SOE and identify according to the electrode number. In summary, valuable information could be collected on the electrode position in the cochlear by means of imaging and SOE measurement.

Because of the extended indication of cochlear implantation, also patients with vestibular schwannoma (VS) and deafness undergo hearing rehabilitation by means of CI. In this context, an intraoperative testing of the hearing nerve after VS resection is reasonable in order to decide whether CI indication can be made. For this purpose, MedEL Company has developed a cochlear test electrode that was conceived for the intraoperative measurement of the function of the hearing nerve. If the preservation of the hearing nerve cannot be assured in cases of tumor resection, the “cochlear test electrode” (► **Fig. 3**) can be inserted into the cochlea like a CI electrode and the hearing nerve is stimulated within the cochlea. If the hearing nerve is intact, electrically evoked brainstem re-

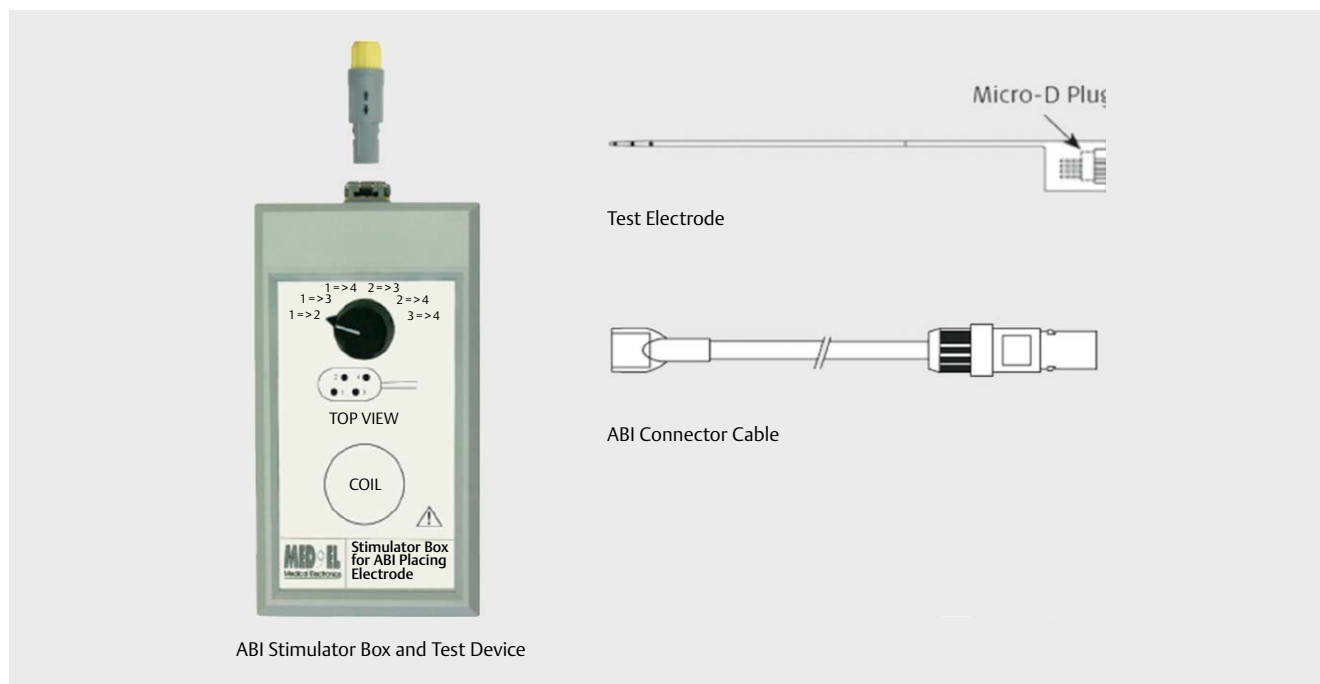

► **Fig. 3** Cochlear Test Electrode (courtesy of MedEL).

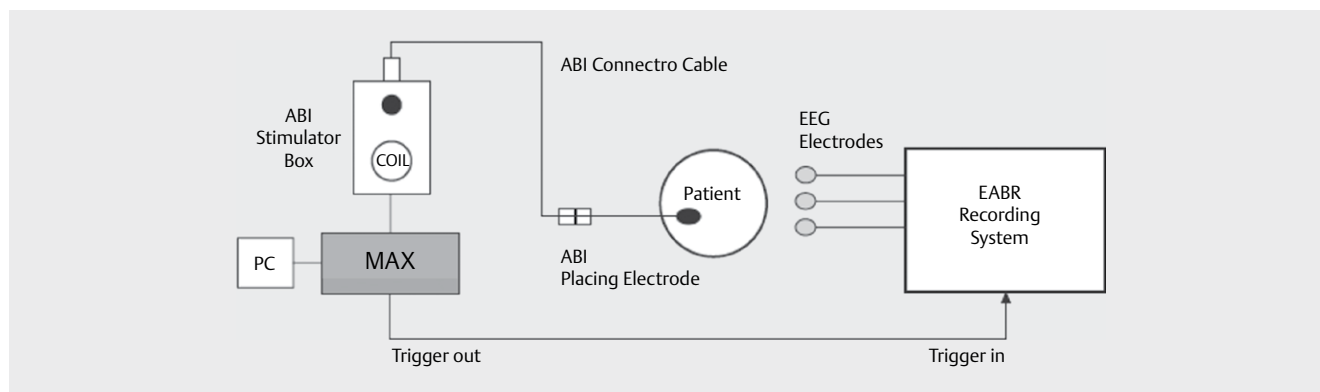

► **Fig. 4** Setup of eABR measurement by means of Cochlear Test Electrode (courtesy of MedEL).

sponses (eABR) can be registered. For this measurement, the cochlear test electrode is necessary (► **Fig. 3**) as well as an ABI connection cable, ABI stimulator box, eABR measurement device, and EEG electrodes (► **Fig. 4**).

In their trial, Lassaletta et al. [71] report about the application of the intracochlear test electrode in 10 CI patients. After identification of the round window, the test electrode was first inserted intraoperatively in order to measure the eABR responses, then it was removed, the CI was implanted and again the eABR responses were measured. The measurement results of the test electrode and the CI were compared and no significant differences with regard to the latencies and amplitudes could be revealed. In their study, Cinar et al. [30] describe the application of the intracochlear test electrode in patients with malformations of the inner ear. The test electrode was used in order to find a decision for cochlear implant or for auditory brainstem implant (ABI) based on the measured eABR.

It could be further revealed that the positive eABR measurements decreased with higher degrees of malformation.

In summary, the cochlear test electrode should be applied in cases of resections of vestibular schwannomas with unclear status of the hearing nerve because positive eABR measurements indicate successful hearing rehabilitation with cochlear implant. Further studies on cochlear test electrodes are expected.

5. Digitization in The Context of Cochlear Implant Rehabilitation

5.1. Digitization in the postoperative phase

After successful cochlear implantation, the phase of follow-up follows that can be divided into three parts according to [13], i. e. basic therapy (day 1 after surgery to 6 weeks post-surgery), consecutive

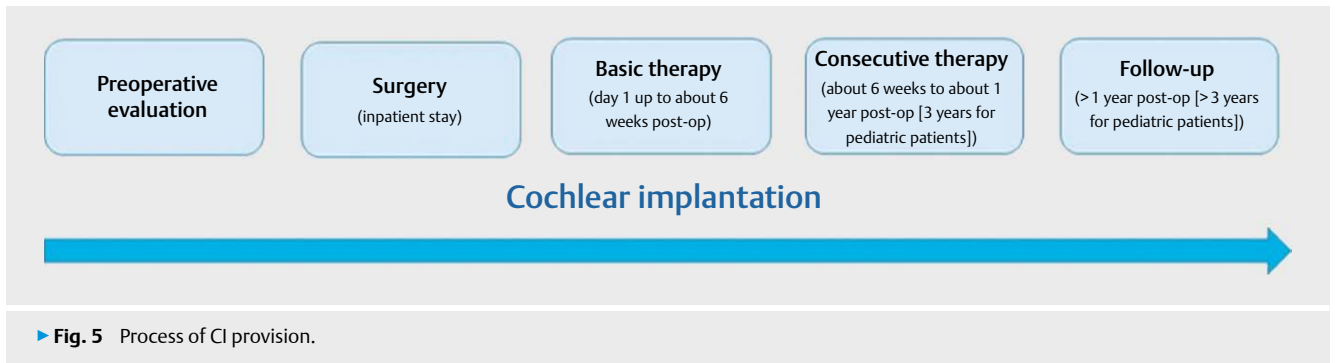

therapy (about 6 weeks to 1 year (3 years for pediatric patients) post-surgery), and finally the life-long follow-up (► Fig. 5) with generally 1 year intervals.

5.1.1. Basic therapy

After initial healing, the first fitting of the sound processor is performed. Depending on the CI center, the date is chosen individually and is usually fixed within the first 6 weeks after surgery. Sometimes, the first “test stimulation” is performed on the first or second day post-surgery, but generally the first stimulation and the first fitting of the speech processor occur in the same session.

This first “hearing” with the cochlear implant is an extremely emotional and challenging situation for newly implanted patients. They do not know exactly what they will experience. Irrational fears and sorrow and great excitement are frequently seen.

With this emotional background, the patients come for first fitting. From here, the patient should be released with a possibly promising speech processor; already this procedure requires a high amount of concentration and cooperation by the patient. In addition, the patient receives a lot of information on handling the technology including extensive accessories that he has to cope with.

How can this challenge be best managed? One possibility could be to subdivide the first fitting, which is very time-consuming for the implanting institution as well as for the patient, into two or more sessions. Another time- and cost-saving option could be the reduction of the time required for fitting the speech processor and preservation of the patient’s mental capacities by applying fitting processes based on objective data, if standard parameters are used. In this context, fitting supported by intraoperatively measured compound action potential (CAP) turned out to be suitable in children as well as in adults. Smoorenburg et al. [73] could show a significant correlation between the steepness of the psychophysical thresholds and the NRT threshold ($r=0.82$) in 27 adult CI24M users. The more detailed procedure of individual definition of channel-specific threshold and comfort levels may take place in later sessions for fine-tuning of the fitting.

5.1.2. Consecutive therapy

After basic therapy, the consecutive therapy follows for about one year in adults and about 3 years in pediatric patients that may be classified into audiological and hearing therapeutic treatment [13].

The aim of parties contributing to the rehabilitation process is the increased quality of the healthcare provision with at the same

time increased efficiency of the used resources by means of **automation** and **standardization**. As already elucidated in the introduction, growing numbers of patients with reduced staff and financial resources present an extraordinary challenge. This situation forces to find effective innovations in the context of long-term CI follow-up. Hereby, digitization of all processes plays a key role.

Some challenges that have already been mentioned will have to be faced by the concerned parties (hospitals, rehabilitation institutions, patients, relatives). Those are for example:

- Healthcare provision for growing numbers of patients with constant staffing
- Healthcare provision for always older patients for whom the frequent way to the rehabilitation institution is a problem
- Discrepancy between offered appointments in the rehabilitation institution and desired dates of the patients due to professional obligations
- Reduced possibilities/readiness of the patients to seize frequent rehabilitation appointments because of important professional/family-related stress
- Difficulty to seize follow-up appointments because of long distances in areas with low population density and only few rehabilitation institutions

The patients’ wish as well as the claim of the hospitals exists that possibly many complex hearing situations may be better managed. For this purpose, sometimes additional technology is necessary that makes control of the CI system more complex and thus more difficult especially for older patients.

Cochlear implants are more and more applied also in “low and middle income countries” (LMICs) where the follow-up is insufficiently organized.

5.2. Possible solution – digitization

It is obvious that the processes associated with CI follow-up need to be optimized.

In the following areas, digital applications are already used or at least feasible from a current point of view:

5.2.1. Digitization in audiological consecutive therapy

The **application of objective measurement procedures** to assess individual variances, e. g. the use of automatically or manually measured compound action potentials (CAP) for manual fitting [73], may lead to shorter durations of the single fitting process.

Sometimes, fitting may even be performed by less experienced/qualified staff.

(Semi-)automatic fitting procedures based on individual patient data combined with expert knowledge gained from large patient cohorts (big data) are more and more distributed.

In this context, meanwhile for example extensive experiences exist with the computer-assisted fitting assistant FOX (Fitting to Outcomes eXpert). Artificial intelligence is expected to allow more rapid and consistent fitting of cochlear implants and thus better hearing quality.

The FOX function is very similar to a navigation system in road traffic that knows the starting point and the destination, disposes of an immense knowledge about possible pathways, and finally calculates the most effective route, e. g. regarding distance or duration, from a multitude of possible roads.

FOX uses audiological data such as hearing threshold, phoneme discrimination, speech audiogram (e. g. measured by Auditory Speech Sounds Evaluation (ASSE, Otoconsult Company)), and loudness scale as basis for an algorithm for optimized implant fitting. The audiological test results are the respective starting point for automated optimization.

FOX provides the possibility to analyze the test results and older MAPs of the patient compared to other anonymized MAPs in order to recommend the best possible MAP. In this way the fitting process is accelerated and the measurement results are closer to the ideal situation. By including new MAPs and performance data in the database, the predictive capacities of FOX are continuously improved.

In a multi-center trial with 27 postlingually deafened adult patients with HiRes90K™ (Advanced Bionics Company), Battmer et al. [74] have investigated the difference of the efficiency and duration of fitting with FOX and a conventional fitting method. They could reveal that the required time in the first two weeks after first fitting for FOX is significantly lower than conventional fitting. Over the further period of the first six months, the needed time of both procedures was similar. A reduction of the variability of the fitting

results between different centers due to the implementation of FOX was described.

In a retrospective trial, Meeuws et al. [75] could show the learning capacity of the FOX algorithm in 25 postlingually deafened adult patients (14 with an implant of Cochlear Company, 11 with Advanced Bionics) with a middle CI useful life of 10 years. Speech understanding could be increased by means of FOX programming compared to “own” MAP.

Also Vaerenberg et al. [76] could reveal the advantage of FOX in eight newly implanted, postlingually deafened adult patients with HiRes90K™ (Advanced Bionics Company). They see the benefit in a systematized CI programming, reduction of the fitting duration, and optimized hearing results.

Simplified fitting procedures based on CAP with **use of standard parameters** have proven to be justified. In this context, for example the Nucleus Fitting Software (NFS) of Cochlear Company must be mentioned that can be very flexibly applied with a tablet computer and a wireless POD. So fitting is not obligatorily bound to the lab situation in an audiometry room, but it can be performed in various environment situations. A fitting expert is not necessarily required; in uncomplicated routine cases, fitting may also be performed in the sense of remote fitting by trained staff such as hearing care professionals. The bases of fitting are automatically determined CAP thresholds as well as punctually measured threshold and comfort levels. Botros et al. [77] could show in 13 patients that the outcome after fitting with NFS software was not significantly different from the one with Custom Sound.

In this context, questions of quality monitoring to avoid wrong fittings have to be solved.

Remote fitting/remote care with video support may assist the fitting of patients who live far away. Hereby even wound control via photo or video camera might be taken into consideration (► Fig. 6).

The patient is linked to the interacting center via remote data connection. The expert in the implanting department or CI center may observe the patient and interact with him. A direct access to the implant is possible if needed, via a qualified person on site or an interface that is controlled by the patient himself. In this way,

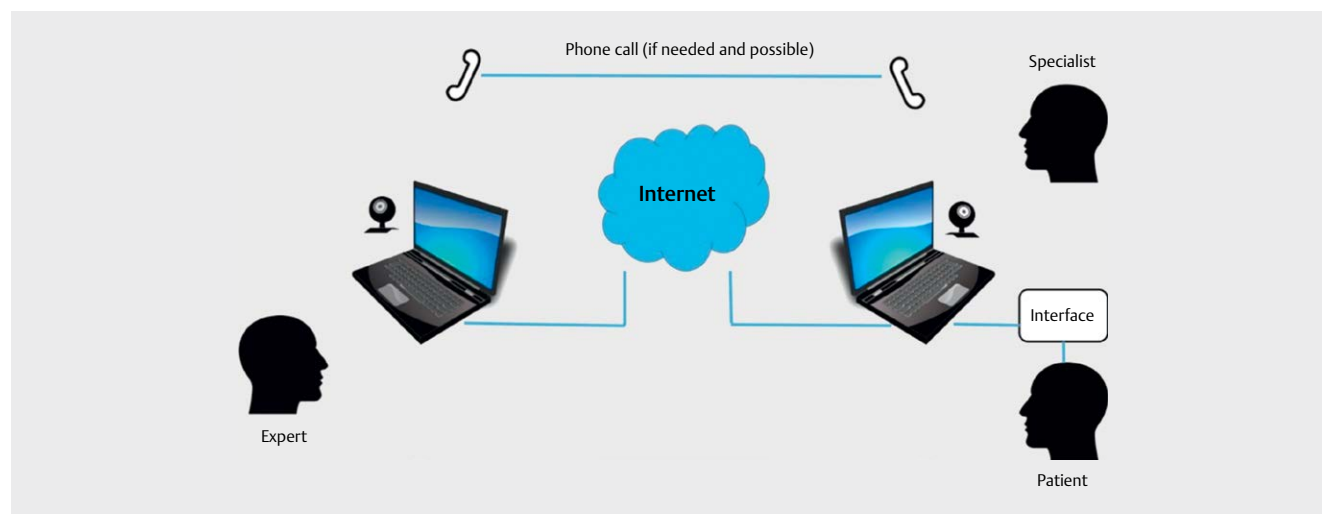

► Fig. 6 Remote fitting.

fine-tuning in particular in the home environment, technical check-ups, and software upgrades may be performed [78].

Eikelboom et al. [79] have developed a computer-based remote fitting system for patients provided with MedEL implants and evaluated it with 11 patients. Remote mapping took 42 minutes on average compared to conventional fitting that took 37 minutes. In the subsequently performed speech test (Ling Six Test, answering of questions), no significant difference between both MAPs could be found. Six patients preferred none of both MAPs, two preferred conventional MAP, and three remote MAP. A delay between audio and video channel was reported, which made communication between the patient and the expert difficult because the mouthings could not be used to support communication. Hereby, the help by the qualified person on site was required. Ten patients finally stated that they wanted to make use of remote fitting; all eleven patients would recommend the procedure.

Kuzovkov et al. [80] report very positively about remote fittings in 33 patients in Italy, Sweden, and Russia. Hereby, a fitting expert from the hospital, the patient, and a local moderator (trained/qualified person) on the patient's side were involved. 96.9% of the patients were satisfied with the fitting outcome, 100% agreed to further remote fitting.

Also Wasowski et al. [81] confirm the efficiency of remote fitting compared to face-to-face fitting. The patients are spared long ways, sometimes even the frequency of fittings may be increased.

Using automatized algorithms based on CAP thresholds, the patients may perform **self-fitting**. They can adapt volume and frequencies themselves, if needed even the comfort and threshold levels.

[77] compares the outcome of self-fitting with the CR110 remote assistant of Cochlear Ltd. with the result of fitting by an audiological expert by means of custom sound. Also hereby, no significant difference could be revealed.

Irrespective of whether fitting was performed in a hospital or rehabilitation institution, remote fitting with home-near secondary partners (local trained/qualified person), or self-fitting, **wire-**

less programming nowadays allows a much more comfortable coupling to the fitting system for the patients. Especially for pediatric patients an important step forward in direction of improving the acceptance of the fitting situation was achieved.

Due to **internet connection**, there is the possibility today to early detect problems (e. g. increased electrode impedances – possible hint to labyrinthitis onset [78]).

Remote troubleshooting (e. g. [82]) may help patients to analyze and handle problems with the sound processor or accessories without having to consult a service partner or even the implanting institution. Possibly unnecessary sending of spare parts or exchange processors can be avoided.

A very charming option of modern CI systems is **data logging**. In the context of fittings, it allows collecting experiences about the use of single MAPs, about the variability and timely weighting of the patient's hearing situation, about his hearing habits regarding the settings of loudness and sensitivity, and finally also about the duration of use. These insights are not only relevant for the hearing professionals and therapists, but also for CI manufacturers.

Success monitoring in the sense of assessing speech understanding is also possible telemedically by means of respective computer software/apps. The quality of life may be assessed and evaluated via questionnaires in the computer- or app-based way.

"Artificial intelligence", "cloud connectivity", and "wireless technology" are terms that show in which direction CI follow-up will go and what is already in use today. As already mentioned in the introduction, a close networking (► Fig. 5) of all parties involved in the rehabilitation process (patient, implanting department, rehabilitation institution, manufacturer, service partner, sometimes also secondary care institution) with efficient data exchange based on applicable regulations of data protection may lead to economic savings, rapid and improved treatment outcome, increased patient satisfaction, and knowledge gain through big data.

► Fig. 7 shows the significance that the single elements of CI follow-up will have in the future. In particular in the context of life-long follow-up, remote care and self-care will play a key role. This



► Fig. 7 Maslow's hierarchy of needs (courtesy of Cochlear Ltd.).

corresponds to the patients' need of optimal and safe function of their cochlear implant without the necessity to make appointments in central institutions that might be far away. Nonetheless, there is the wish that the function and possibly arising dysfunctions are monitored by experts, which will be possibly based on telemedicine. This is perfectly in line with the objectives of the cost bearers regarding cost reduction and the constraints of hospitals and rehabilitation institutions to optimally use human resources. In this way, the "standard patient" with simple needs for provision can be cared more comfortably and even more safely on the long term, while experts may spend more time on special cases that require much individual attention.

It must be critically discussed that the very positive aspects of remote and self-fitting only apply for patients without special audiological or other particularities. A major part of old and very old patients have a high need for individual care and are not able to perform self- or remote fitting. According to the authors' experience, it is not possible for a significant percentage of the patients to use auto-CAP because higher pulse widths are necessary to generate evaluable CAP responses, which is not provided by the auto-routine. In cases of specific problems such as poor acceptance, increasing tinnitus with CI therapy, deviations from the regular tonotopy, discomfort, or co-stimulation of the facial nerve by single electrodes etc., automatized procedures cannot be applied.

Moreover, a broadband internet connection as it is necessary for remote fitting and care, is not available everywhere.

Nonetheless, the time savings may be important in uncomplicated "standard patients" due to simplified fitting procedures or remote care, which is then beneficial for "problem patients".

5.2.2. Digitalization in hearing therapeutic follow-up

Also in the context of **hearing training**, the standardization and comparability plays a crucial role. This requirement is best met by the use of computer-based hearing training programs, as for example AudioLog by Flexsoft. The superiority compared to Life Speech is obvious since standardized and calibrated speech and sound output ensure comparable training and test situations in different sessions and the comparability between different centers.

In particular, isolated training and testing of the implanted ear may be very well achieved and defined via wireless accessories by direct streaming of hearing training contents into the sound processors.

The results of **data logging** are very helpful to retrieve information about the usage habits and the hearing environment of the patients and to provide tips for program usage and hearing behavior.

Outcome measurement with direct feeding of test material into the sound processor (e. g. Auditory Speech Sounds Evaluation [ASSE]) allow testing in rooms that do not meet the high acoustic preconditions and ensure the isolated testing of the implanted ear without co-listening or overhearing of the contralateral ear.

CI users may participate in telemedical rehabilitation programs via telephone or internet. The remote rehabilitation sessions are similar to face-to-face sessions and allow patients to discuss with rehabilitation experts without undertaking long journeys.

5.2.3. Advantages of digitization for patients regarding daily CI usage

Digitization has fundamentally changed the patients' handling of the cochlear implant. While the option of setting loudness parameters and the selection between several programs had already been possible with pocket speech processors, the controlling options were significantly different already with the first remote controls.

Nowadays, the individual options of intervention become more and more extensive from one device generation to the next; and handling of the CI is increasingly comfortable.

Signal processing, partly even with **automatic situation recognition** and automatic adaptation with the objective to manage complex hearing situation in the best possible way (e. g. scan program, Cochlear Company Ltd.), is successfully applied by most patients.

Manual options of adapting to the respective hearing situation via **remote control** are meanwhile a matter of course.

Today the vast majority of patients disposes of smartphones and uses them very actively. Thus, the implementation of smartphones in the speech processor control via **SmartApps** is evident. The options widely exceed the known parameter settings with traditional remote control devices.

- Program selection
- Setting of loudness and microphone sensitivity
- MVBT (Cochlear Ltd.): setting of **MasterVolume**, **Bass**, **Treble**
- Audiostreaming
- Availability of using data for the patient (percentage of use with speech, number of "coil-offs")
- Battery control
- Sound processor search

Wireless accessories have revolutionized the use of cochlear implants. Whether to find interference-free pleasure in listening to music, to gain back the capacity of understanding TV independently from the distance to it, being able to acoustically reach a CI-wearing child ahead of you, or understanding presenters in lectures without worrying about the seating position, the possibilities of audiostreaming significantly improve the hearing situation of patients. For the patients, the easy handling and interference-free phoning is a great benefit; with the use of a phone adapter or by means of Bluetooth there is no need to take out the phone from the pocket. The option to stream the sound signal directly into the speech processor has become a standard for hearing training in the rehabilitation institution as well as for exercising with audiobooks.

Already in the chapter on hearing screening, the unmanageable number of available health apps for android and iOS was mentioned, among them for example **hearing test apps**, otoscope apps, hearing training apps.

In the context of basic and follow-up therapy, apps may be used for orienting success control, but also hereby the statement formulated by Bright et al. [83] is true that the currently available apps cannot replace the gold standard, i. e. PTA performed by specialists. Due to the low costs, the portability, and the easy access, such apps may be suitable to accompany therapy, in particular in countries with insufficient healthcare provision.

The hardware plays a crucial role. A calibrated transducer is required with respective linear or at least known frequency response that can be balanced by the app.

Furthermore, apps are available that allow **individual hearing training** by means of smartphones. The results are documented; the training success can be verified with statistical graphs. In German speaking countries, the most common apps are Asklepios Hör-training by the Hanseatic Cochlear Implant Center and Listen Up! by MedEl. These apps do not replace the hearing training accompanied by specialists in a rehabilitation institution, but if continuously applied, they may support the rehabilitation process and motivate the patients.

As already mentioned in the introduction, **data storage in central systems** as well as networking is already implemented today in the context of caring for CI patients, for example the network of implanting hospitals, rehabilitation institutions, service partners (e.g. hearing care professionals), and CI manufacturers. In this way, for example service queries can be efficiently answered (► Fig. 8). There is no need for the service provider to search where the current MAP is stored, to reach the respective contact person, and to wait until the data are forwarded – which might lead to a delay in delivering the spare part for one or two working days. Of course, each type of networking with involved partners where patient-related data are shared, is subject to the applicable regulations of data protection that have to be observed thoroughly.

5.2.4. Improvement of bilateral hearing by digital signal processing and control

The objective of each type of hearing aid provision is **binaural hearing** as well as possible. Particularly in patients who receive two cochlear implants or bimodal hearing solutions (CI in one ear, hearing aid in the other ear), modern digital technique has an enormous potential for improvement. It is already possible that two speech processors or one hearing aid and one speech processor communicate and cooperate. In this way, focusing on one speaker in noise can be significantly optimized (StereoZoom). The direction from where the “sound has to be heard” can be defined comfortably (ZoomControl); the sound of the telephone can be easily heard in both ears although the receiver is placed only on one side (Duo-

Phone); both sides can be switched with only one keystroke (Quick-Sync) [84]. (► Fig. 9)

In cases of bilateral hearing loss where CI provision is only possible in one ear, there is the possibility to treat with a very comfortable CROS device (Naida Link CROS) [85].

6. Follow-up – Digitization – CI

6.1. What does “CI follow-up” mean?

CI rehabilitation is subdivided into different phases (see chapter on “Digitization in the postoperative phase”); the life-long follow-up is an integral part. According to the recommendations of the German Society of Oto-Rhino-Laryngology, the follow-up starts about one year after surgery in adults and about four years post-surgery in children. It starts immediately after consecutive therapy and lasts for the whole life.

CI follow-up is structured into three parts, the audiological, technical, and medical follow-up/control. The objective of follow-up should be the stabilization and optimization of the communicative abilities [13].

6.2. Challenges from the patients’ perspective

For the life-long follow-up of cochlear implant patients, important logistic and staff-related efforts are required. Possibly, the patient is stressed with high timely efforts and associated work loss, cost-intensive transportation as well as disturbed family life [86]. Moreover, lifestyle aspects have to be considered, i. e. for personal reasons, patients prefer follow-up independently from their location.

6.3. Challenges from the hospitals’ perspective

The increasing number of hearing impaired subjects and the resulting number of CI users lead to the necessity of process optimization with the background of the increasing cost pressure.

Promising strategies for preservation of a maximal healthcare are required. The challenge hereby is to make available high-end

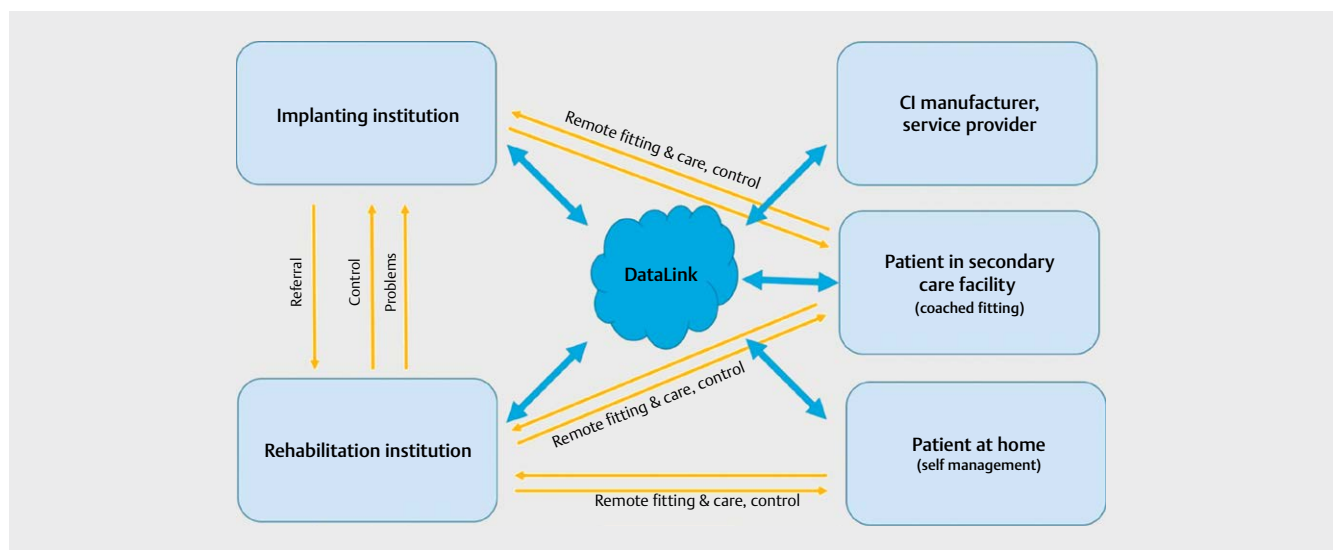

► Fig. 8 Networking in the follow-up process.

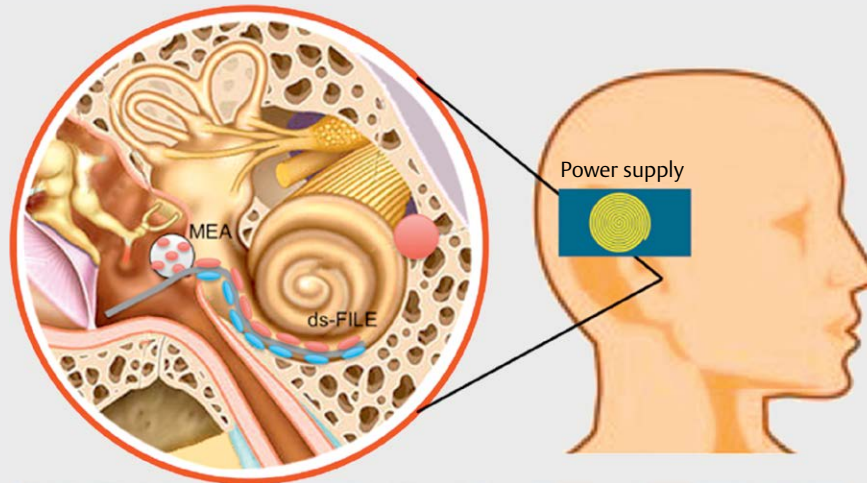

► **Fig. 9** Investigations on tinnitus suppression by electrical stimulation applying a multi-electrode array (MEA) at the round window or a micro-electrode (ds-FILE = double-sided – filament electrode). Quelle: „Forschungsprogramm zur Mensch-Technik-Interaktion: Technik zum Menschen bringen“ des BMBF, Verbundprojekt INTAKT, Förderkennzeichen 16SV7875.

medicine for all patients and to enhance the competences in the treating institutions.

Digitization may contribute enormously in this context; however, regarding the introduction of internet-based services, the expansion of the internet bandwidth has to be observed. Urban areas do not represent a problem, but more rural areas have been repeatedly disadvantaged in the last years with regard to bandwidth expansion [87]. So the defined objective of the current government is to establish a nationwide coverage with broadband access until 2025 [88].

6.4. Solutions for CI follow-up

Saunders and Chisolm [89] defined four application and development areas of tele-audiology (see introduction) that are conceptually applied in the context of follow-up in order to meet these requirements by using digital media. This tele-audiological options overlap in the three follow-up modalities of technical, medical, and audiological CI follow-up.

In the context of technical follow-up, for example remote consultations or CAP measurements can be performed online by video or phone conferences. Furthermore, consultations as “store and forward” (see chapter on “Applications of tele-audiology”) and CAP measurements can be imagined in the context of remote monitoring.

Medical follow-up as merely telemedical offer is subject to specific regulations that are elucidated by another contribution in this manual. Considering the technical options in an isolated manner, video conferences with face-to-face contact seem to be suitable. Also during follow-up, clinical examinations can be displayed via so-called otoscopy apps, as already described in the chapter on screening [90].

The probably most interesting possibilities when considering digitization are seen in audiological follow-up that regularly takes place in cases of peculiarities during technical follow-up. Beside the

mentioned options of personal patient contact, for example mobile healthcare services for self-control and self-management of speech processor settings as well as for hearing and speech test controls are helpful.

6.5. Hearing training in CI follow-up

Hearing training mainly occurs in the context of basic and consecutive therapy after cochlear implantation (see chapter on basic therapy). However, the provision of life-long hearing training and thus the development of hearing training during follow-up are highly interesting.

In order to improve speech understanding, the leading CI manufacturers and other institutions offer specific applications [91]. They originate from the evidence of auditory rehabilitation of one-to-one situations and provide the possibility of auditory or audiovisual training. Computer-based applications prove to increase the motivation of hearing training which is most probably the highest benefit of these applications for an improved speech perception [5, 89].

6.6. Remote care networks

The expertise of the treatment center can be retrieved via so-called remote care networks by associated remote institutions, e. g. less specialized hospitals, hearing care professionals, or rehabilitation institutions. The exchange may also occur on an interdisciplinary level [92]. These connected institutions should cover a primary service such as controls of the hearing ability or technical check-ups and in cases of problems get the expertise of the hospital. Technically, this may be realized via a web-based face-to-face contact. The connected expert may then perform parameter settings of the speech processor and retrieve data such as specific using data.

The following technologies are also used in remote care networks:

- Wireless technologies, e. g. real-time data exchange with smartphones
- Artificial intelligence, e. g. for automated setting of cochlear implants as well as control of parameter settings in the follow-up
- Cloud-based networks for data exchange for example with specialized hospitals, patients, rehabilitation institutions, subordinate hospitals

The services of remote care networks have to be adapted specifically to the location. In rural areas the knowledge transfer with a broad-scale effect is necessary in order to minimize unnecessary transportation of patients and to reduce associated time-consuming and financial efforts. In urban regions, this is also required; however, due to the high density of specialized healthcare institutions, the focus is rather placed on immobile patients or on data exchange with distant rehabilitation institutions.

6.7. Evidence of telemedical CI follow-up

In 2018, the University of Southampton and the team around Cullington [86, 93] performed a two-arm controlled randomized trial (RCT) with the objective to evaluate the long-term follow-up via internet-based remote follow-up. Both study arms encompassed 30 patients each and had a duration of 6 months. They tested the speech understanding, the patient self-management with CI, the self-reported subjective hearing perception, and the quality of life. The authors report that the remote care group had a significantly better speech understanding and a higher score regarding the self-management after 6 months of study onset; this means the patients had a better knowledge regarding their CI and reported overall better skills for handling the CI. In contrast, the control group reported significantly poorer scores for subjective self-assessment of the hearing capacity. After 6 months, the quality of life was similar in both groups. The limitation of this first RCT (according to the authors) on follow-up of CI patients consisted of the fact that telemedical follow-up is no universal option for all cochlear implant patients, but rather has to be individually discussed in the context of shared decision making.

6.8. Outcome

The feasibility of internet-based follow-up could be demonstrated, which at the same time can be used for assessment of the outcome. Questionnaire-assisted evaluations, for example regarding the quality of life or the subjective hearing perception, can be provided online without any problem. Even during an appointment in the hospital it is possible to retrieve data electronically for example via tablet and to access them via large databases. However, the process of big data requires prior agreements on standardization that should be achieved in the context of consensus finding. The problems of too small study groups were often mentioned in the past. The significant heterogeneity of assessment tools between national and international centers is crucial in this context. Repeatedly, we suggested in own publications to apply the psychometric test battery of the Charité, Berlin [5–8, 10–12, 20]; the tool assessing the quality of life (NCIQ) was included in the white paper on cochlear implantation in April 2018.

In particular for the definition of small effects, high numbers of cases are necessary. Predictors for future cochlear implantations

might be determined and indications confirmed. In the context of “data logging”, the possibility arises to link outcome data with other patient-related data and thus to develop individual concepts for patients based on detailed analyses, finally even by further development of artificial intelligence.

6.9. Perspectives

Telemedical treatment and follow-up concepts have already reached advanced stages in other medical disciplines, e. g. cardiology or psychiatrics. In the context of cochlear implantation, this development is still at its beginning of a very promising innovation of existing follow-up modalities. Based on the statements of Cullington and co-workers, it may be expected that telemedicine in cochlear implantation will be an additional tool, however, up to now it cannot completely replace the examination on site [86, 93].

7. Innovation Cluster on Interactive Micro-implants (INTAKT)

Project coordination: Fraunhofer Institute for Biomedical Engineering IBMT

Tinnitus suppression

Finally, we want to present a research project of our department in the context of the INTAKT consortium project that fits perfectly in the topic of hearing rehabilitation in the era of digitization. It illustrates how the future might be in the field of hearing implants.

The objective of the INTAKT project is the development, manufacturing, characterization, and pre-clinical evaluation of a new generation of active, networking implants. They dispose of interfaces allowing physicians and patients an easy information access for participative decision making. The precondition is the needs-based, transparent description of all necessary information about the status and the functionality of the implants including their contact to biological tissue. By adapting the parameters and modes to the respective needs of the patients, these new interactive options allow improved and expanded functions of the implanted systems and thus provide the possibility of personalized, individual patient healthcare.

To realize this innovative approach of the INTAKT project, a network of up to 12 interactive micro-implants is being developed, implemented, and pre-clinically tested. The intelligent communication between the implants themselves as well as with a central external communication unit and the evaluation of the assessed signals takes place based on the principles of information processing, i. e. filtering of signals, compressing data processing, pattern recognition, standard routines etc. This allows a temporally better synchronization of a multitude of activities. In this way, the micro-implants largely approach physiological circumstances in their functionality and may thus better and more complexly compensate impairments due to functional deficits.

The intelligence of the system consists of coupling internal and external systems on the basis of safe data exchange. Another advantage regarding traditional implants is that the network of micro-implants is not only active in one location, but takes into account the functionality of larger correlated tissue sections and organs as a whole. In this way, pathological changes cannot only be influenced punctually, but in a physiological way and interactively in several locations with treatment.

If needed, the networking implants communicate with the patients and the medical staff via external interfaces. In this way, a personalized adaptation of the implant network to the patients' current needs becomes possible. So, interactive control of the needs replaces rigid stimulation algorithms. Such individualized, multi-local, and interactive implants are the basis for numerous relevant application scenarios.

Within this issue, tinnitus suppression by means of micro-implants plays an important role. Due to new technological possibilities, treatment options arise allowing the application for the treatment of patients. Other fields of application concern the treatment of functional disorders of the gastrointestinal tract and the development of a neuromuscular stimulator for realization of gripping functions.

7.1. Problem description

Tinnitus is defined as subjective perception of noise despite a missing external acoustic source. It is no clearly defined disease, but a symptom that may be caused by several origins (e. g. hearing disorders, cardiovascular or neurological diseases, diabetes, or tumors).

Tinnitus is frequently associated with hearing disorders, but it is also observed as independent symptom. Dysfunctions of the hearing systems are assumed to be responsible. The guideline on chronic tinnitus summarizes the current knowledge regarding the pathophysiology of tinnitus [94]. According to most recent psycho- and neurophysiological investigations on the mechanisms of neuronal plasticity, peripheral as well as central changes seem to play a major role.

The need for treatment is justified by the persistence of an important level of suffering and existing or developing comorbidities. The level of suffering is individually very different and does not correlate with the tinnitus frequency or loudness [95]. The significant individual differences can be explained mainly by the variety and severity of accompanying symptoms and diseases such as depressions, sleep and concentration disorders etc. [96].

The crucial factor for therapeutic intervention in the chronic stage is the severity of tinnitus. For chronic tinnitus, there is no causal treatment method. Especially cognitive and multimodal behavioral therapies are applied in order to avoid severe complications caused by tinnitus stress. Furthermore, hearing therapeutic interventions such as training, hearing aids, or cochlear implants may be applied [94–97].

Nonetheless, patients with a high tinnitus strain may experience important impairment of the ability to work and psychological decompensation despite the application of all therapeutic options. Beside the enormous impairment of the quality of life, this is associated with high socio-economic expenses. So, a reliably effective procedure for treatment tinnitus complaints would be highly relevant from a medical as well as socio-economic point of view.

7.2. Thematic objectives

Epidemiological investigations could show that the tinnitus prevalence amounts to 5–15% [98]. In Germany, about 10 million people suffer from tinnitus. In 10% of these individuals, treatment is required. In the USA, only the expenses for tinnitus treatment in the group of war veterans amount to 1 billion US dollars.

Already since the 1970ies, therapeutic approaches of influencing tinnitus by means of electrostimulation of the cochlea are pursued.

The effects of electrical stimulation in the context of cochlear implantation on tinnitus have been investigated in numerous trials. The current literature confirms positive effects of CI on tinnitus in a high number of CI users [6, 8, 11, 12, 99–105]. Own studies reveal that besides improved speech understanding, CI also leads to an improved quality of life, tinnitus and stress, and psychological comorbidities [5–9, 11, 12, 41, 105].

Consequently, the thematic objectives of the development of special extracochlear implants for tinnitus patients are highly relevant – independently from the hearing situation.

The technical possibilities of miniaturization today allow following new pathways of transmitting electrostimulation. Physiologically, the effect on the tinnitus shall be achieved by synchronization of the afferent signals of the cochlea as well as the support of central neuromodulation by modifying the afferent signals. The individually adapted stimulation leads to a needs-appropriate individualized suppression of the tinnitus. In cases of bilateral audiological symptoms, communication of the stimulation units is required for adaptation of the stimulation parameters.

7.3. Objective, role, and project tasks

The following university and non-university research institutions, small and medium-sized companies, and major enterprises contribute to this 13.5 million Euro project: Fraunhofer Society (IBMT), University of Mainz, Germany, University of Heidelberg, Germany, Charité – University Medicine of Berlin, Germany, University of Mannheim, Germany, Technical University of Ilmenau, Germany, GeSiM (Gesellschaft für Silizium-Mikrosysteme mbH), inomed Medizintechnik GmbH, Soventec GmbH, Wilddesign GmbH & Co. KG, IL Metronic Sensortechnik GmbH, Glück Engineering GmbH, Würth Eletronik GmbH & Co. KG, VARTA Microbattery GmbH, Heraeus Medical Components, CeramTec-ETEC GmbH, and CETECOM ICT Services GmbH. The Department of Otolaryngology of the Charité – University Medicine of Berlin has to accomplish the following tasks:

- The objective of the project part is the assessment of stimulation parameters on electrical suppression of tinnitus as well as characterization of the patient cohort.
- Evaluation of an implant manufactured by the project partners with regard to implantation possibility and check of the proof of concept.
- Testing of the stimulation parameters of clinical evaluations in an animal model.
- The role of the ENT Department of the Charité - University Medicine of Berlin consists of the clinical assessment of stimulation parameters for tinnitus suppression and of performing animal experiments.

The task comprises the performance and evaluation of the clinical study, the conduction and evaluation of animal experimental trials, and the adaptation or interruption of the studies or parts of it depending on the outcome resulting in the context of the project.

The innovation and attractiveness of the approach consist in the combination of a clinical study with evaluation and preselection of a clinically heterogenic patient cohort (tinnitus patients) and the

implementation of these data in an animal model using an innovative implant system.

The particularity of this procedure is testing an implant prototype that has to be developed and that may lead to the treatment of a nearly untreatable disease in a clinically simple way (unmet need).

Even if the idea of electrostimulation for tinnitus treatment has already been described for a longer time, the clinical implementation fell short because of the failing development of clinically applicable systems for electrostimulation. In the context of the innovation cluster of INTAKT, the implants to be developed might open new possibilities.

8. Closing Remarks

In this article, current and future developments of digital application are described and discussed from the perspective of a cochlear implanting hospital.

Due to the increasing number of subjects with hearing disorders, among others based on the demographic development, due to the extended CI indications that are associated with a high variability especially in the context of binaural provision with hearing systems and resulting higher number of CI users, the necessity arises to find new pathways with the background of limited resources.

Also for the life-long follow-up of patients with cochlear implants, high logistic and staff-related efforts are necessary. Also the lifestyle aspects have to be taken into consideration, i. e. many patients wish a follow-up independently from their location that may be integrated into their daily routine. The use of digital media open new possibilities of cochlear implantation for mobility-impaired people with hearing disorders and for those who have to travel long distances to reach the next specialized institution and thus to overcome the barrier of the face-to-face contact.

The objective of all efforts undertaken by people contributing to the rehabilitation process is to increase the quality of CI provision with at the same time increased efficiency of the applied resources. In this context, digitization plays a key role.

The article illustrates manifold digital applications that may be implemented in all phases of cochlear implantation, starting with information and screening of potential candidates via preoperative evaluation and consultation, surgery and ending up with postoperative basic and consecutive therapy and life-long follow-up as well as clinical research.

Artificial intelligence, cloud connectivity, and wireless technology are terms that show where we are heading in the context of CI and where we are already right now.

Many patients retrieve information prior to medical consultations and wish an active self-empowerment. This becomes possible by telemedicine and medical apps. Simplified fittings (MAP creation) can be realized for example by (semi-)automatic MAP (e. g. NFS, FOX, or other AI applications). Telemedicine, remote care networks, and apps allow local care for CI users. Telemedical concepts provide complete innovations of patients' care with active participation of the patients themselves such as automated technical implant control, remote care, self-programming, and technological upgrades. Central databases may store current MAP for example in repair cases and document technical data and hearing performance.

Some of the applications described above are already reality, other are being developed.

The current developments show that digitization in the medical field progresses rapidly. Even if still many preconditions and details have to be designed for the implementation of digital media in medicine, this innovation is absolutely needed.

Considering the advantages of digitization, also limitations must be discussed and patients and other actors of healthcare services have to be involved actively into this process. For example remote and self-fitting can only be applied for patients without special audiological or other particularities.

Regarding safety and data protection in Germany – that are subject to the specific laws such as data protection law, telecommunication law, and telemedia law – it will certainly be a challenge that the single user always keeps control of his own data.

The discussion about the digital progress may help finding a framework for digital regulations because without the expertise of the actors in the healthcare system, also quality management of medical services with AI will not be possible, at least in the near future. So, we are all invited to actively contribute to this process. For us as otorhinolaryngologists this means that we have to meet the requirements of qualification and education with regard to digital applications beside a high specific professional expertise.

Acknowledgements

The authors of this article want to express their thankfulness towards all those who contributed relevantly to this topic by manifold input, vivid discussions, and the provision with information and figures. We particularly thank the companies of Cochlear, MedEl, and Advanced Bionics.

Conflict of Interest

The author states that there is no conflict of interests.

References

- [1] WHO. Deafness and hearing loss. In 2018
- [2] Lin FR, Metter EJ, O'Brien RJ et al. Hearing Loss and Incident Dementia. *Archives of Neurology* 2011; 68: 214–220
- [3] Lin FR, Ferrucci L, An Y et al. Association of hearing impairment with brain volume changes in older adults. *NeuroImage* 2014; 90
- [4] Lin FR. Hearing loss and cognition among older adults in the United States. *J Gerontol A Biol Sci Med Sci* 2011; 66: 1131–1136
- [5] Knopke S, Gräbel S, Förster-Ruhrmann U et al. Impact of cochlear implantation on quality of life and mental comorbidity in patients aged 80 years. *Laryngoscope* 2016; 126
- [6] Olze H, Gräbel S, Förster U et al. Elderly patients benefit from cochlear implantation regarding auditory rehabilitation, quality of life, tinnitus, and stress. *Laryngoscope* 2012; 122: 196–203
- [7] Olze H, Knopke S, Gräbel S et al. Rapid Positive Influence of Cochlear Implantation on the Quality of Life in Adults 70 Years and Older. *Audiology and Neurotology* 2016; 21

- [8] Olze H, Gräbel S, Haupt H et al. Extra benefit of a second cochlear implant with respect to health-related quality of life and tinnitus. *Otology & neurotology: Official publication of the American Otological Society, American Neurotology Society [and] European Academy of Otolaryngology and Neurotology* 2012; 33: 1169–1175
- [9] Knopke S, Szczepek AJ, Haussler SM et al. Cochlear Implantation of Bilaterally Deafened Patients with Tinnitus Induces Sustained Decrease of Tinnitus-Related Distress. *Front Neurol* 2017; 8: 158
- [10] Hirschfelder A, Gräbel S, Olze H. The impact of cochlear implantation on quality of life: the role of audiologic performance and variables. *Otolaryngology–head and neck surgery: Official journal of American Academy of Otolaryngology-Head and Neck Surgery* 2008; 138: 357–362
- [11] Olze H, Szczepek AJ, Haupt H et al. Cochlear implantation has a positive influence on quality of life, tinnitus, and psychological comorbidity. *Laryngoscope* 2011; 121: 2220–2227
- [12] Olze H, Szczepek AJ, Haupt H et al. The impact of cochlear implantation on tinnitus, stress and quality of life in postlingually deafened patients. *Audiol Neurootol* 2012; 17: 2–11
- [13] DGHNO Pd. Weißbuch Cochlea-Implantat(CI)-Versorgung
- [14] Blamey PJ, Maat B, Başkent D et al. A Retrospective Multicenter Study Comparing Speech Perception Outcomes for Bilateral Implantation and Bimodal Rehabilitation. *Ear Hearing* 2015; 36: 408–416
- [15] Lenarz T. [Cochlear Implant - State of the Art]. *Laryngorhinotologie* 2017; 96: S123–S151
- [16] Knopke S, Szczepek AJ, Häussler SM et al. Cochlear Implantation of Bilaterally Deafened Patients with Tinnitus Induces Sustained Decrease of Tinnitus-Related Distress. *Frontiers in Neurology* 2017; 8: 158–158
- [17] Disorders NIodaOC. Cochlear Implants. In: 2017
- [18] Bundesamt S Bevölkerung und Erwerbstätigkeit. 2015, DOI: 1 - 69
- [19] Deutschen Gesellschaft für Hals-Nasen-Ohren-Heilkunde K-uH-CeV, Bonn. Cochlea-Implantat Versorgung und zentral-auditorische Implantate. In: 2012
- [20] Knopke S, Olze H. Hörrehabilitation mithilfe von Cochleaimplantaten und kognitive Fähigkeiten. *HNO* 2017, doi:10.1007/s00106-017-0423-z
- [21] Mathers C, Smith A, Concha M. Global burden of hearing loss in the year. 2000,
- [22] Sohn W, Jorgenshaus W. Hals-Nasen-Ohren-Erkrankungen-Schwerhörigkeit in Deutschland-Representative Horscreening-Untersuchung bei 2000 Probanden in 11 Allgemeinpraxen. *ZFA-Zeitschrift für Allgemeinmedizin-Ausgabe A* 2001; 77: 143–147
- [23] Teschner M, Polite C, Lenarz T et al. Cochlear implantation in different health-care systems: Disparities between Germany and the United States. *Otology & Neurotology* 2013; 34: 66–74
- [24] Hoppe U, Hast A, Hocke T. Audiometry-based screening procedure for cochlear implant candidacy. *Otology & Neurotology* 2015; 36: 1001–1005
- [25] Sorkin DL. Cochlear implantation in the world's largest medical device market: Utilization and awareness of cochlear implants in the United States. *Cochlear implants international* 2013; 14: S12–S14
- [26] Bionics A <http://www.AdvancedBionics.de> In 2018;
- [27] Cochlear www.cochlear.de In 2018;
- [28] Medel www.medel.com In 2018;
- [29] Oticon www.oticonmedical.com In 2018;
- [30] Aiello CP, Ferrari DV. Teleaudiology: efficacy assessment of an online social network as a support tool for parents of children candidates for cochlear implant. In, *CoDAS: SciELO Brasil* 2015; 411–418
- [31] Institute I <https://idainstitute.com/> In ; 2018;
- [32] Paglialonga A, Nielsen AC, Ingo E et al. eHealth and the hearing aid adult patient journey: A state-of-the-art review. *Biomedical engineering online* 2018; 17: 101
- [33] Uecker FC, Szczepek AJ, Olze H. Paediatric bilateral cochlear implantation: Simultaneous versus sequential surgery. *Otol Neurotol* 2018; in press
- [34] Hinderink JB, Krabbe PF, Van Den Broek P. Development and application of a health-related quality-of-life instrument for adults with cochlear implants: The Nijmegen cochlear implant questionnaire. *Otolaryng Head Neck* 2000; 123: 756–765
- [35] Holube I, Kollmeier B. Modifikation eines Fragebogens zur Erfassung des subjektiven Hör-verDLögens und dessen Beziehung zur Sprachverständlichkeit in Ruhe und unter Störgeräuschen. 1994,
- [36] Nasreddine ZS, Phillips NA, Bédirian V et al. The Montreal Cognitive Assessment, MoCA: A brief screening tool for mild cognitive impairment. *Journal of the American Geriatrics Society* 2005; 53: 695–699
- [37] Smits C, Theo Goverts S, Festen JM. The digits-in-noise test: assessing auditory speech recognition abilities in noise. *The Journal of the Acoustical Society of America* 2013; 133: 1693–1706
- [38] Hoppe U, Hocke T, Hast A et al. Langzeitergebnisse eines Screeningverfahrens für erwachsene Cochlea-Implantat-Kandidaten. *Laryngo-Rhino-Otologie* 2017; 96: 234–238
- [39] Bright T, Pallawela D. Validated smartphone-based apps for ear and hearing assessments: A review. *JMIR rehabilitation and assistive technologies* 2016; 3
- [40] Nast DR, Speer WS, Le Prell CG. Sound level measurements using smartphone" apps": Useful or inaccurate? *Noise and Health* 2014; 16: 251
- [41] Bruggemann P, Szczepek AJ, Klee K et al. In Patients Undergoing Cochlear Implantation, Psychological Burden Affects Tinnitus and the Overall Outcome of Auditory Rehabilitation. *Front Hum Neurosci* 2017; 11: 226
- [42] Hinderink JB, Krabbe PF, Van Den Broek P. Development and application of a health-related quality-of-life instrument for adults with cochlear implants: the Nijmegen cochlear implant questionnaire. *Otolaryngology–head and neck surgery: Official journal of American Academy of Otolaryngology-Head and Neck Surgery* 2000; 123: 756–765
- [43] Sweetow RW. Screening for cognitive disorders in older adults in the audiology clinic. *Audiology Today* 2015; 27: 38–43
- [44] Morris MA, Saboury B, Burkett B et al. Reinventing radiology: Big data and the future of medical imaging. *Journal of thoracic imaging* 2018; 33: 4–16
- [45] Brink JA, Arenson RL, Grist TM et al. Bits and bytes: the future of radiology lies in informatics and information technology. *European radiology* 2017; 27: 3647–3651
- [46] Radiology ES0. Summary of the proceedings of the international forum 2016: "Imaging referral guidelines and clinical decision support-how can radiologists implement imaging referral guidelines in clinical routine?". *Insights into imaging* 2017; 8: 1–9
- [47] Kansagra AP, John-Paul JY, Chatterjee AR et al. Big data and the future of radiology informatics. *Academic radiology* 2016; 23: 30–42
- [48] Gerber N, Bell B, Gavaghan K et al. Surgical planning tool for robotically assisted hearing aid implantation. *International Journal of Computer Assisted Radiology and Surgery*. 2014; 9: 11–20
- [49] Lu P, Barazzetti L, Chandran V et al. Facial nerve image enhancement from CBCT using supervised learning technique. In *Engineering in Medicine and Biology Society (EMBC), 2015 37th Annual International Conference of the IEEE: IEEE* 2015; 2964–2967
- [50] Mellor JC, Stone MA, Keane J. Application of data mining to "big data" acquired in audiology: Principles and potential. *Trends in hearing* 2018; 22: 2331216518776817

- [51] Cox S, Oakes M, Wermter S et al. AudioMine: Medical Data Mining in Heterogeneous Audiology Records. World Academy of Science, Engineering and Technology, International Journal of Computer, Electrical, Automation, Control and Information Engineering 2007; 1: 141–144
- [52] Czaplik M, Voigt V, Kenngott H et al. Why OR. NET? Requirements and perspectives from a medical user's, clinical operator's and device manufacturer's points of view. Biomedical Engineering/Biomedizinische Technik 2018; 63: 5–10
- [53] Kasparick M, Schmitz M, Andersen B et al. OR. NET: A service-oriented architecture for safe and dynamic medical device interoperability. Biomedical Engineering/Biomedizinische Technik 2018; 63: 11–30
- [54] Benzko J, Krause L, Janß A et al. Modular user interface design for integrated surgical workplaces. Biomedical Engineering/Biomedizinische Technik 2016; 61: 183–197
- [55] Klenzner T, Ngan CC, Knapp FB et al. New strategies for high precision surgery of the temporal bone using a robotic approach for cochlear implantation. European archives of oto-rhino-laryngology 2009; 266: 955
- [56] Caversaccio M, Gavaghan K, Wimmer W et al. Robotic cochlear implantation: Surgical procedure and first clinical experience. Acta Oto-Laryngol 2017; 137: 447–454
- [57] Cosetti MK, Troob SH, Latzman JM et al. An evidence-based algorithm for intraoperative monitoring during cochlear implantation. Otology & Neurotology 2012; 33: 169–176
- [58] Viccaro M, Covelli E, De Seta E et al. The importance of intra-operative imaging during cochlear implant surgery. Cochlear implants international 2009; 10: 198–202
- [59] Vogl T, Tawfik A, Emam A et al. Pre-, intra-and post-operative imaging of cochlear implants. In Röntgen-Fortschritte auf dem Gebiet der Röntgenstrahlen und der bildgebenden Verfahren: © Georg Thieme Verlag KG 2015; 980–989
- [60] Carelsen B, Grolman W, Tange R et al. Cochlear implant electrode array insertion monitoring with intra-operative 3D rotational X-ray. Clinical Otolaryngology 2007; 32: 46–50
- [61] Aschendorff A. Imaging in cochlear implant patients. GMS current topics in otorhinolaryngology, head and neck surgery 2011; 10
- [62] Bloom JD, Rizzi MD, Germiller JA. Real-time intraoperative computed tomography to assist cochlear implant placement in the malformed inner ear. Otology & Neurotology 2009; 30: 23–26
- [63] Yuan Y-Y, Song Y-S, Chai C-M et al. Intraoperative CT-guided cochlear implantation in congenital ear deformity. Acta Oto-Laryngol 2012; 132: 951–958
- [64] Stelter K, Ledderose G, Hempel JM et al. Image guided navigation by intraoperative CT scan for cochlear implantation. Computer Aided Surgery 2012; 17: 153–160
- [65] Shapiro WH, Huang T, Shaw T et al. Remote intraoperative monitoring during cochlear implant surgery is feasible and efficient. Otology & Neurotology 2008; 29: 495–498
- [66] Yanov Y, Kuzovkov V, Sugarova S et al. Successful application and timing of a remote network for intraoperative objective measurements during cochlear implantation surgery. International journal of audiology 2018; DOI: doi: 1–7
- [67] Botros A, van Dijk B, Killian M. AutoNRT™: An automated system that measures ECAP thresholds with the Nucleus® Freedom™ cochlear implant via machine intelligence. Artificial Intelligence in Medicine 2007; 40: 15–28
- [68] van Dijk B, Botros AM, Battmer R-D et al. Clinical results of AutoNRT,™ a completely automatic ECAP recording system for cochlear implants. Ear Hearing 2007; 28: 558–570
- [69] Tavartkiladze G, Bakhshinyan V, Irwin C. Evaluation of new technology for intraoperative evoked compound action potential threshold measurements. International journal of audiology 2015; 54: 347–352
- [70] Grolman W, Maat A, Verdam F et al. Spread of excitation measurements for the detection of electrode array foldovers: A prospective study comparing 3-dimensional rotational x-ray and intraoperative spread of excitation measurements. Otology & Neurotology 2009; 30: 27–33
- [71] Lassaletta L, Polak M, Huesers J et al. Usefulness of Electrical Auditory Brainstem Responses to Assess the Functionality of the Cochlear Nerve Using an Intracochlear Test Electrode. Otology & Neurotology 2017; 38: e413–e420
- [72] „vom“, . DOI, 2018, 34
- [73] Smoorenburg GF, Willeboer C, van Dijk JE. Speech perception in nucleus CI24M cochlear implant users with processor settings based on electrically evoked compound action potential thresholds. Audiol Neurootol 2002; 7: 335–347
- [74] Battmer R-D, Borel S, Brendel M et al. Assessment of 'Fitting to Outcomes Expert' FOX™ with new cochlear implant users in a multi-centre study. Cochlear Implants International 2015; 16: 100–109
- [75] Meeuws M, Pascoal D, Bermejo I et al. Computer-assisted CI fitting: Is the learning capacity of the intelligent agent FOX beneficial for speech understanding? Cochlear Implants Int 2017; 18: 198–206
- [76] Vaerenberg B, Govaerts PJ, de Ceulaer G et al. Experiences of the use of FOX, an intelligent agent, for programming cochlear implant sound processors in new users. Int J Audiol 2011; 50: 50–58
- [77] Botros A, Banna R, Maruthurkkara S. The next generation of Nucleus((R)) fitting: a multiplatform approach towards universal cochlear implant management. Int J Audiol 2013; 52: 485–494
- [78] Lenarz T. Cochlear implant - state of the art. GMS Curr Top Otorhinolaryngol Head Neck Surg 2017; 16 Doc04
- [79] Eikelboom RH, Jayakody DMP, Swanepoel DW et al. Validation of remote mapping of cochlear implants. J Telemed Telecare 2014; 20: 171–177
- [80] Kuzovkov V, Yanov Y, Levin S et al. Remote programming of MED-EL cochlear implants: users' and professionals' evaluation of the remote programming experience. Acta Oto-Laryngologica 2014; 134: 709–716
- [81] Wasowski A, Skarzynski PH, Lorens A et al. Remote fitting of cochlear implant system. Cochlear implants international 2010; 11: (Suppl 1): 489–492
- [82] Frago LM, Canon S, de la Rosa EJ et al. Programmed cell death in the developing inner ear is balanced by nerve growth factor and insulin-like growth factor I. J Cell Sci 2003; 116: 475–486
- [83] Bright T, Pallawela D. Validated Smartphone-Based Apps for Ear and Hearing Assessments: A Review. JMIR Rehabilitation and Assistive Technologies 2016; 3: e13–e13
- [84] Bionics A. Die neue bimodale Naída Hörlösung.
- [85] Bionics A. Die Naída Link CROS Lösung.
- [86] Cullington H, Kitterick P, Weal M et al. Feasibility of personalised remote long-term follow-up of people with cochlear implants: A randomised controlled trial. BMJ open 2018; 8: e019640
- [87] Infrastruktur BfVud. <https://www.bmvi.de/DE/Themen/Digitales/Breitbandausbau/Breitbandatlas-Karte/start.html> In 2018
- [88] FAZ. <http://www.faz.net/aktuell/wirtschaft/diginomics/so-weit-ist-deutschland-mit-dem-breitbandausbau-15672719.html> In 2018
- [89] Saunders GH, Chisolm TH. Connected audiological rehabilitation: 21st century innovations. J Am Acad Audiol 2015; 26: 768–776
- [90] Bush ML, Thompson R, Irungu C et al. The role of telemedicine in auditory rehabilitation: A systematic review. Otology & neurotology: official publication of the American Otological Society, American Neurotology Society [and] European Academy of Otology and Neurotology 2016; 37: 1466

- [91] Pichora-Fuller MK, Levitt H. Speech comprehension training and auditory and cognitive processing in older adults. *American Journal of Audiology* 2012; 21: 351–357
- [92] Krüger-Brand HE. Mobile Medizintechnik: Telemedizin für die Nachsorge. *Dtsch Arztebl International* 2013; 110: 2014–2015
- [93] Cullington HE, Agyemang-Prempeh A. Person-centred cochlear implant care: Assessing the need for clinic intervention in adults with cochlear implants using a dual approach of an online speech recognition test and a questionnaire. *Cochlear implants international* 2017; 18: 76–88
- [94] Zenner H, Delb W, Kröner-Herwig B et al. On the interdisciplinary S3 guidelines for the treatment of chronic idiopathic tinnitus. *Hno* 2015; 63: 419–427
- [95] Folmer RL, Griest SE, Meikle MB et al. Tinnitus severity, loudness, and depression. *Otolaryngology—Head and Neck Surgery* 1999; 121: 48–51
- [96] Kreuzer PM, Vielsmeier V, Langguth B. Chronic tinnitus: An interdisciplinary challenge. *Deutsches Ärzteblatt International* 2013; 110: 278
- [97] Mazurek B, Szczepek AJ, Bruggemann P. [Tinnitus - Clinical Symptoms and Therapy]. *Laryngorhinotologie* 2017; 96: 47–59
- [98] Henry JA, Dennis KC, Schechter MA. General review of tinnitus: prevalence, mechanisms, effects, and management. *Journal of speech, language, and hearing research* 2005; 48: 1204–1235
- [99] Baguley DM, Atlas MD. Cochlear implants and tinnitus. *Progress in brain research* 2007; 166: 347–355
- [100] Kompis M, Pelizzone M, Dillier N et al. Tinnitus before and 6 months after cochlear implantation. *Audiology and Neurotology* 2012; 17: 161–168
- [101] Miyamoto RT, Bichey BG. Cochlear implantation for tinnitus suppression. *Otolaryngologic Clinics of North America* 2003; 36: 345–352
- [102] Pan T, Tyler RS, Ji H et al. Changes in the tinnitus handicap questionnaire after cochlear implantation. *American journal of audiology* 2009; 18: 144–151
- [103] Quaranta N, Fernandez-Vega S, D'Elia C et al. The effect of unilateral multichannel cochlear implant on bilaterally perceived tinnitus. *Acta Oto-Laryngol* 2008; 128: 159–163
- [104] Quaranta N, Wagstaff S, Baguley DM. Tinnitus and cochlear implantation. *International Journal of Audiology* 2004; 43: 245–251
- [105] Olze H. Cochlear implants and tinnitus. *HNO* 2015; 63: 291–297